

50	Volant <i>Handwheel</i>	Alpax AS13 Y30 <i>Alpax</i>
23	Boulonnerie du fouloir <i>Gland bolting</i>	Acier A60/classe 10 <i>Steel A 572 Gr 65 / A 194 Gr 2H</i>
21	Garniture <i>Packing</i>	Graphite <i>Graphite</i>
12	Ecrou de tige <i>Stem nut</i>	Acier S300 Pb <i>Steel A 29 Gr 12L14</i>
11	Tige <i>Stem</i>	Acier inox Z 20 C13 <i>Stainless steel AISI 420</i>
7	Joint corps/chapeau <i>Body/bonnet gasket</i>	Graphite <i>Graphite</i>
6	Boulonnerie corps/chapeau <i>Body/bonnet bolting</i>	Acier classe 10/9 <i>Steel A 193 Gr B7 / A 194 Gr 2H</i>
4	Siège / Portée d'étanchéité <i>Seat / Tightness-seating</i>	Acier inox Z 20 C13 <i>Stainless steel AISI 420</i>
3	Obturateur / Portée d'étanchéité <i>Disc / Tightness-seating</i>	Stellite <i>Stellite</i>
2	Chapeau <i>Bonnet</i>	Acier A 48 CP <i>Steel A 515 Gr 70</i>
1	Corps <i>Body</i>	Acier A 480 CP-M <i>Steel A 216 Gr WCB</i>
REP MARK	DESIGNATION DESIGNATION	MATIERE (AFNOR) MATERIAL (ASTM/AISI)

REFERENCES - REFERENCES

Les nuances ASTM/AISI ne figurent qu'à titre indicatif - *ASTM/AISI materials are not contractual*
 Construction - *Construction* : NFE 29.327 (02/85)
 Raccordement - *Connection* : Brides, ISO PN16, type 21-B, NFE 29.203 (07/89)
 Classe de pression - *Pressure class* : ISO PN16
 Essais - *Testing* : NFE 29.311 (06/82), taux d'étanchéité 2
 Courbe pression / TC - *Pressure / TC curve* : NFE 29.005 (91), ISO 7005-1 (04/92)

OPTIONS - OPTIONS

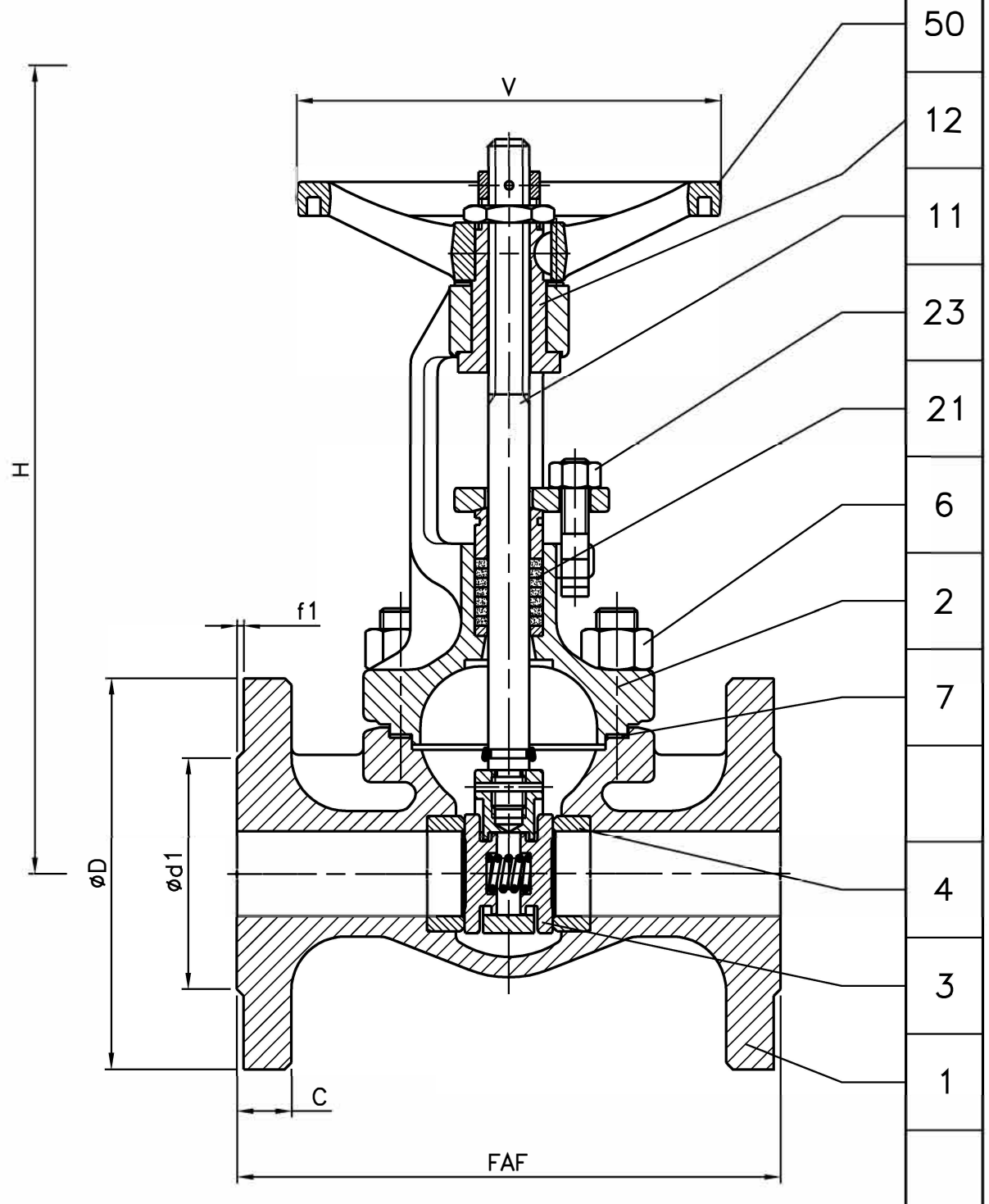

DN	15	20	25	32	40
Catégorie suivant DESP - <i>Type in accordance with PED : 97/23/CE</i>	art.3.3	art.3.3	art.3.3	C1	C1
FAF mm	150	160	160	180	190
øD/C mm	95/16	105/18	115/18	140/18	150/18
Nbr/øTrou/øPerçage Nbr/øHole/øDrilling	4/14/65	4/14/75	4/14/85	4/18/100	4/18/110
ød1/f1 mm	45/2	58/2	68/2	78/2	88/3
V mm	100	100	125	125	160
H (Ouvert) (Opened) mm	210	220	245	265	310
Kv	9.5	20	37	62	105
Masse - <i>Weight</i> kg	4.3	5.2	7.5	11	13

A	20/02/02	C. Longuet	A. Lairault	D. Dunoyer	Etablissement du plan
Indice Index	Date Date	Rédigé Issued by	Vérifié Checked by	Approuvé Approved by	Objet de la modification Modification object
Titre - <i>Title</i>	ROBINET - VANNE "Alpha.S" ISO PN16 GATE VALVE			Figure - <i>Figure</i>	Orifice - <i>Orifice</i>
				3750 07	15 à 40
Toute reproduction est interdite, sans l'autorisation de SNRI					-

