

50	Volant Handwheel	Fonte FGS 400/15 Cast iron A 536 Gr 60-40-18
23	Boulonnerie du fouloir Gland bolting	Acier classe 10/9 Steel A193 Gr.B7/A194 Gr.2H
21	Garniture Packing	Graphite Graphite
12	Ecrou de tige Stem nut	Fonte FGS Ni22 Cast iron A 439 Gr D-2C
11	Tige Stem	Acier inox Z 20 C13 Stainless steel AISI 420
7	Joint corps/chapeau Body/bonnet gasket	Graphite Graphite
6	Boulonnerie corps/chapeau Body/bonnet bolting	Acier classe 10/9 Steel A193 Gr.B7/A194 Gr.2H
4	Siège / Portée d'étanchéité Seat / Tightness-seating	Acier TU 52-b / Stellite Gr 6 Steel A 106 Gr B / Stellite Gr 6
3	Obturateur / Portée d'étanchéité Disc / Tightness-seating	Acier A 42 CP / Stellite Gr 6 Steel A 515 Gr 60 / Stellite Gr 6
2	Chapeau Bonnet	Acier A 480 CP-M Steel A 216 Gr WCB
1	Corps Body	Acier A 480 CP-M Steel A 216 Gr WCB
REP MARK	DESIGNATION DESIGNATION	MATIERE (AFNOR) MATERIAL (ASTM/AISI)

REFERENCES - REFERENCES

Les nuances ASTM/AISI ne figurent qu'à titre indicatif - ASTM/AISI materials are not contractual
 Construction - Construction : NFE 29.327 (02/85)
 Raccordement - Connection : Brides, ISO PN50, type 21-B, NFE 29.203 (07/89)
 Classe de pression - Pressure class : ISO PN50
 Essais - Testing : NFE 29.311 (06/82), taux d'étanchéité 2
 Courbe pression / TC - Pressure / TC curve : NFE 29.005 (91), ISO 7005-1 (04/92)

OPTIONS - OPTIONS

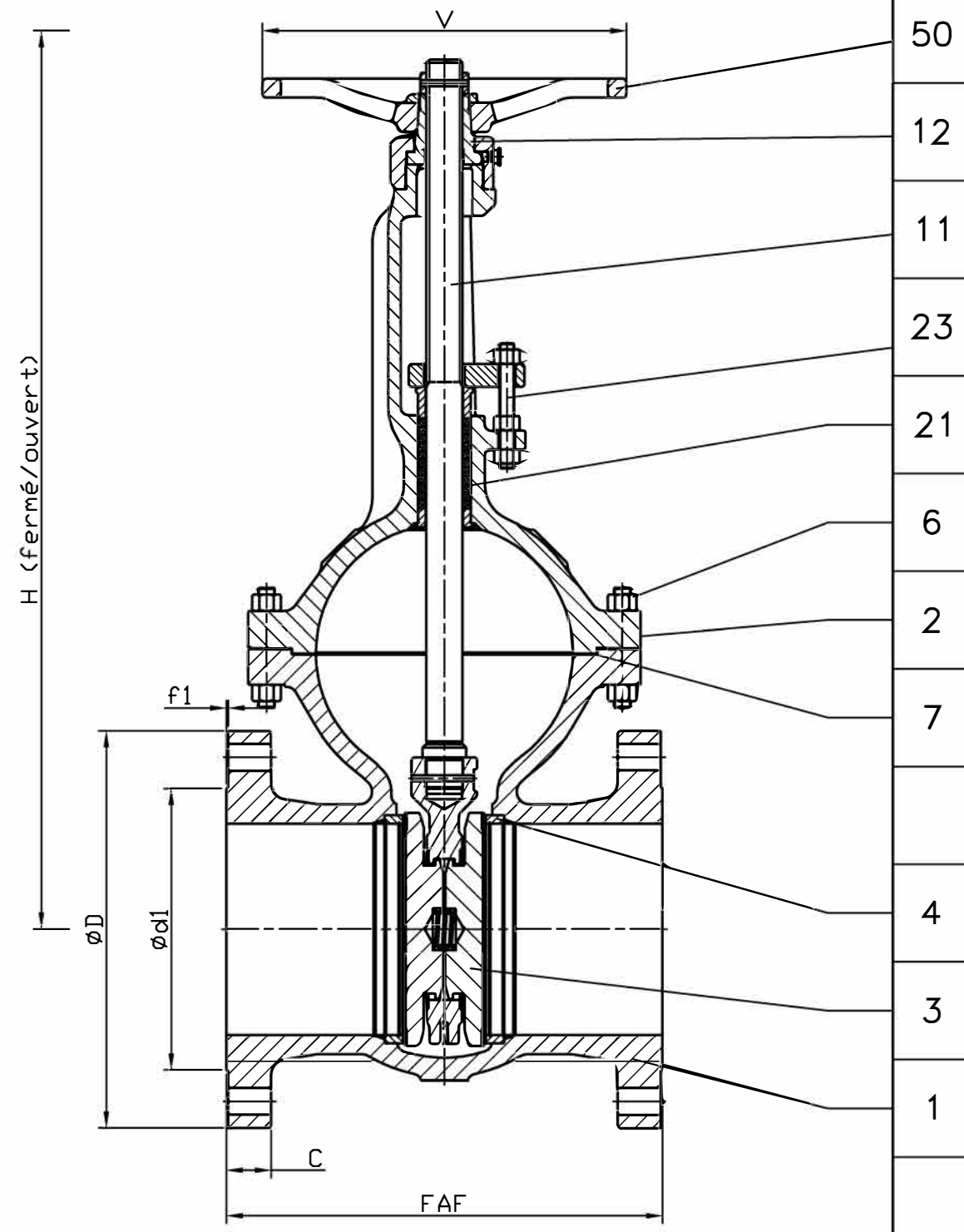

DN	200	250	300						
Catégorie suivant DESP - Type in accordance with PED : 97/23/CE	C3	C3	C3						
FAF mm	419	457	502						
ØD/C mm	381/41.1	444/47.8	521/50.8						
Nbr/ØTrou/ØPerçage Nbr/ØHole/ØDrilling mm	12/25.4/330.2	16/28.5/387.4	16/31.8/450.8						
Ød1/f1 mm	269.9/1.6	323.8/1.6	381/1.6						
V mm	400	500	500						
H (Fermé/Ouvert) (Closed/Opened) mm	836/1048	1000/1267	1179/1497						
Pression limite cde manuelle	25.5	20.5	27						
Kv	4350	7040	10370						
Masse - Weight kg	200	316	474						

B	07.09.04	C. Longuet	A. Lairault	D. Dunoyer	Mise à jour du plan suivant DESP 97/23/CE
A	21/09/98	R. Proust			Etablissement du plan
Indice Index	Date Date	Rédigé Issued by	Vérfié Checked by	Approuvé Approved by	Objet de la modification Modification object
Titre - Title	ROBINET - VANNE "Alpha.S" API 600 GATE VALVE			Figure - Figure	Orifice - Orifice
				2764 60	200 à 300
Toute reproduction est interdite, sans l'autorisation de SNRI					-

