

50	Volant Handwheel	Fonte FGS 400/15 Cast iron A 536 Gr 60-40-18
23	Boulonnerie du fouloir Gland bolting	Acier classe 10/9 Steel A193 Gr.B7/A194 Gr.2H
21	Garniture Packing	Graphite Graphite
12	Ecrou de tige Stem nut	Fonte FGS Ni22 Cast iron A 439 Gr D-2C
11	Tige Stem	Acier inox Z 20 C13 Stainless steel AISI 420
7	Joint corps/chapeau Body/bonnet gasket	Graphite Graphite
6	Boulonnerie corps/chapeau Body/bonnet bolting	Acier classe 10/9 Steel A193 Gr.B7/A194 Gr.2H
4	Siège / Portée d'étanchéité Seat / Tightness-seating	Acier E28.2 / Stellite Gr.6 Steel A 570 Gr 40 / Stellite Gr.6
3	Obturateur / Portée d'étanchéité Disc / Tightness-seating	Acier A 42 CP / Stellite Gr 6 Steel A 515 Gr 60 / Stellite Gr 6
2	Chapeau Bonnet	Acier A 480 CP-M Steel A 216 Gr WCB
1	Corps Body	Acier A 480 CP-M Steel A 216 Gr WCB
REP MARK	DESIGNATION DESIGNATION	MATIERE (AFNOR) MATERIAL (ASTM/AISI)

REFERENCES - REFERENCES

Les nuances ASTM/AISI ne figurent qu'à titre indicatif - ASTM/AISI materials are not contractual
 Construction - Construction : NFE 29.327 (02/85)
 Raccordement - Connection : Brides, ISO PN50, type 21-B, NFE 29.203 (07/89)
 Classe de pression - Pressure class : ISO PN50
 Essais - Testing : NFE 29.311 (06/82), taux d'étanchéité 2
 Courbe pression / TC - Pressure / TC curve : NFE 29.005 (91), ISO 7005-1 (04/92)

OPTIONS - OPTIONS

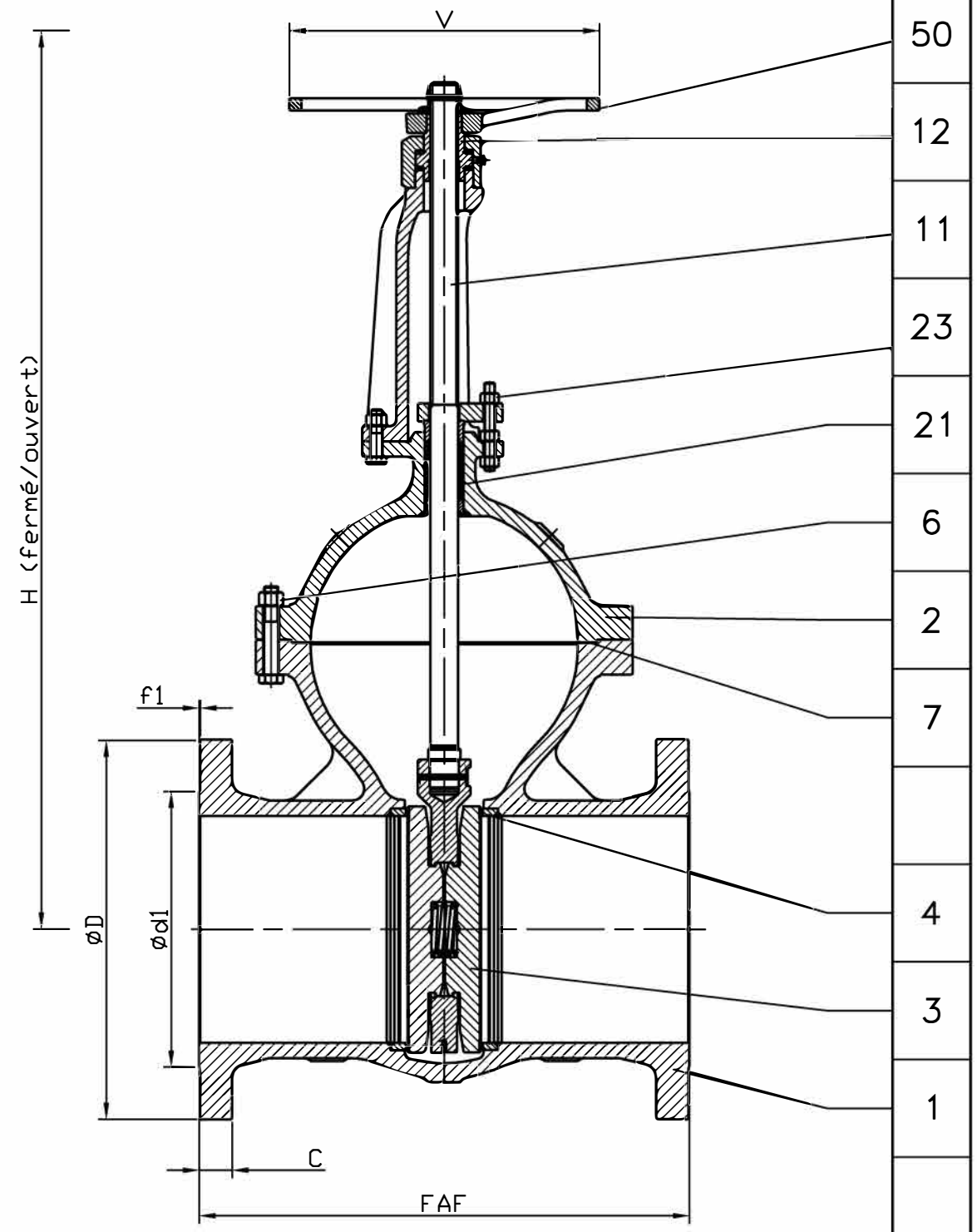

DN	350	400							
Catégorie suivant DESP - Type in accordance with PED : 97/23/CE	C3	C3							
FAF mm	762	838							
ØD/C mm	584/53,8	648/57,2							
Nbr/ØTrou/ØPerçage Nbr/ØHole/ØDrilling mm	20/31,8/514,4	20/35/571,5							
Ød1/f1 mm	412,8/1,6	469,9/1,6							
V mm	600	600							
H (Fermé/Ouvert) (Closed/Opened) mm	1285/1640	1447/1852							
Kv	12180	16360							
Masse - Weight kg	684	840							

A	07.01.03	C. Longuet	A. Lairault	D. Dunoyer	Etablissement du plan
Indice Index	Date Date	Rédigé Issued by	Vérifié Checked by	Approuvé Approved by	Objet de la modification Modification object
Titre - Title	ROBINET - VANNE "Alpha.S" ISO PN50 GATE VALVE			Figure - Figure	Orifice - Orifice
				2764 09	350 à 400
Toute reproduction est interdite, sans l'autorisation de SNRI					