

50	Volant Handwheel	Fonte FGS 400/15 Cast iron A 536 Gr 60-40-18
23	Boulonnerie du fouloir Gland bolting	Acier classe 10/9 Steel A193 Gr.B7/A194 Gr.2H
21	Garniture Packing	Graphite Graphite
12	Ecrou de tige Stem nut	Fonte FGS Ni22 Cast iron A 439 Gr D-2C
11	Tige Stem	Acier inox Z 20 C13 Stainless steel AISI 420
7	Joint corps/chapeau Body/bonnet gasket	Graphite Graphite
6	Boulonnerie corps/chapeau Body/bonnet bolting	Acier classe 10/9 Steel A193 Gr.B7/A194Gr.2H
4	Siège / Portée d'étanchéité Seat / Tightness-seating	Acier TU 52-b / Stellite Gr 6 Steel A 106 Gr B / Stellite Gr 6
3	Obturateur / Portée d'étanchéité Disc / Tightness-seating	Acier A 42 CP / Stellite Gr 6 Steel A 515 Gr 60 / Stellite Gr 6
2	Chapeau Bonnet	Acier A 480 CP-M Steel A 216 Gr WCB
1	Corps Body	Acier A 480 CP-M Steel A 216 Gr WCB
REP MARK	DESIGNATION DESIGNATION	MATIERE (AFNOR) MATERIAL (ASTM/AISI)

REFERENCES - REFERENCES

Les nuances ASTM/AISI ne figurent qu'à titre indicatif - ASTM/AISI materials are not contractual
 Construction - Construction : NFE 29.327 (02/85). Face à face ISO PN 50
 Raccordement - Connection : Embouts à souder BW svt norme NFE 29 032. Forme C2.2 (8/85)
 Classe de pression - Pressure class : ISO PN50
 Essais - Testing : NFE 29.311 (06/82), taux d'étanchéité 2
 Courbe pression / TC - Pressure / TC curve : NFE 29.005 (91), ISO 7005-1 (04/92)

OPTIONS - OPTIONS

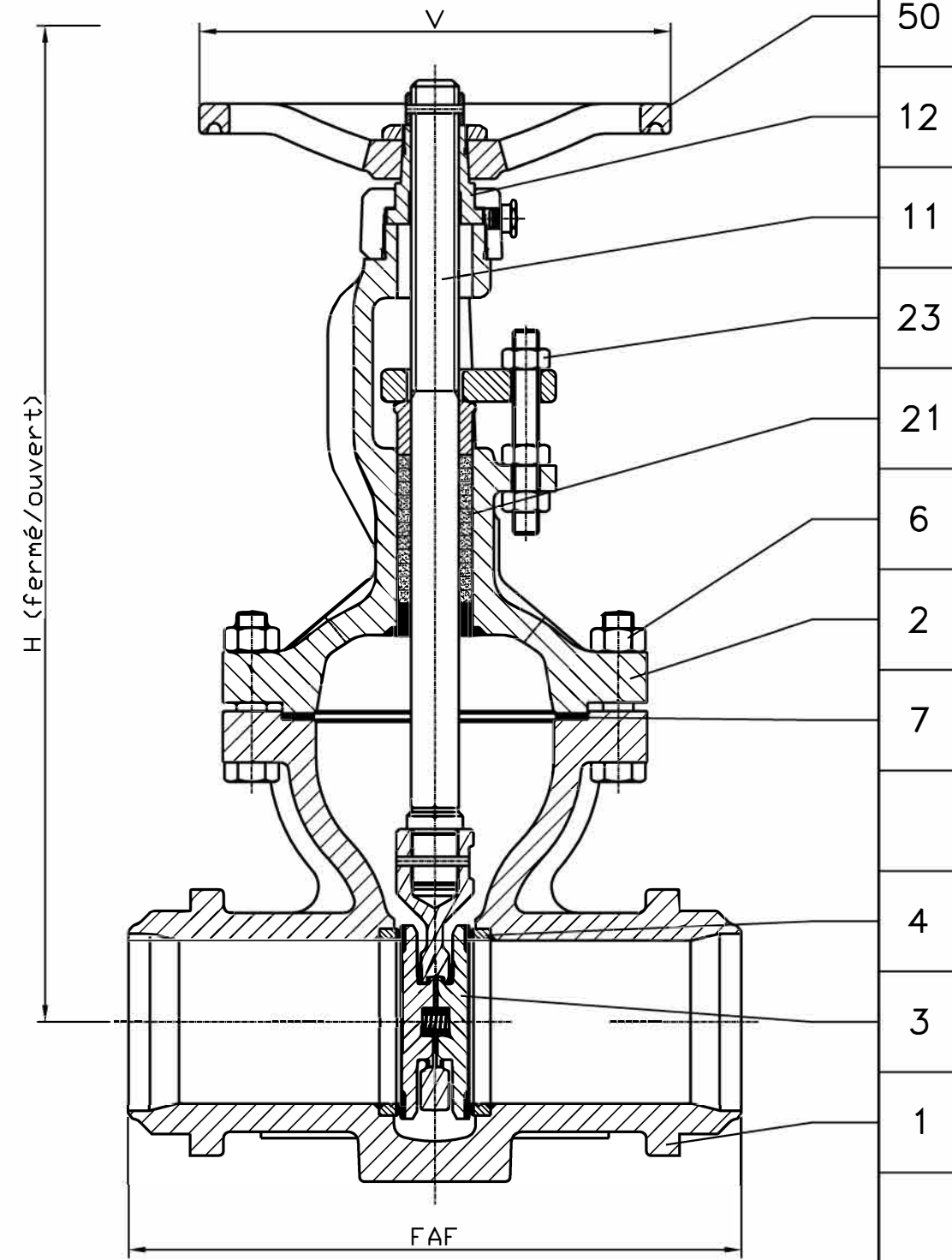
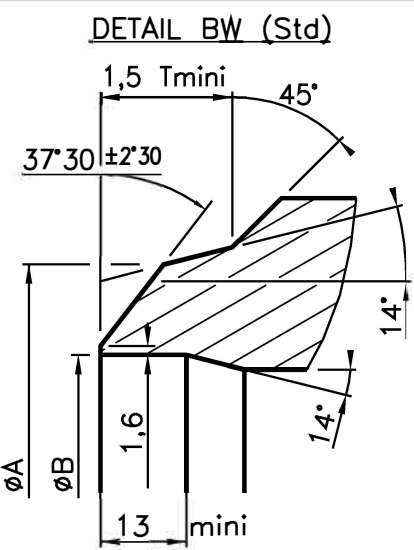

DN	50	65	80	100	125	150
Catégorie suivant DESP - Type in accordance with PED : 97/23/CE	C2	C2	C2	C2	C3	C3
FAF mm	216	241	283	305	381	403
φA mm	62	77	91	117	144	172
φB mm	Selon schédule commande client					
V mm	200	200	250	250	250	315
H (Fermé/Ouvert) (Closed/Opened) mm	352/411	352/411	440/524	525/636	525/636	691/851
Pression limite cde manuelle	-	-	-	-	-	36.5
Kv	240	250	540	1010	1040	2280
Masse - Weight kg	16.5	19	25	48	52	102

C	05/11/02	C. Longuet	A. Lairault	D. Dunoyer	Modification catégorie DN 050 C2 (C1)
B	30.01.02	C. Longuet	A. Lairault	D. Dunoyer	Mise à jour du plan suivant DESP 97/23/CE
A	21/09/98	R. Proust			Etablissement du plan
Indice Index	Date Date	Rédigé Issued by	Vérifié Checked by	Approuvé Approved by	Objet de la modification Modification object

ROBINET - VANNE
 "Alpha.S" ISO PN50
 GATE VALVE

Titre - Title: 2763 | 09 | Orifice - Orifice: 50 à 150

Toute reproduction est interdite, sans l'autorisation de SNRI -

