

50	Volant <i>Handwheel</i>	Fonte FGS 400/15 <i>Cast iron A 536 Gr 60-40-18</i>
23	Boulonnerie du fouloir <i>Gland bolting</i>	Acier classe 10/9 <i>Steel A193 Gr B7 / A 194 Gr 2H</i>
21	Garniture <i>Packing</i>	Graphite <i>Graphite</i>
12	Ecrou de tige <i>Stem nut</i>	Fonte FGS Ni22 <i>Cast iron A 439 Gr D-2C</i>
11	Tige <i>Stem</i>	Acier inox Z 20 C13 <i>Stainless steel AISI 420</i>
7	Joint corps/chapeau <i>Body/bonnet gasket</i>	Graphite <i>Graphite</i>
6	Boulonnerie corps/chapeau <i>Body/bonnet bolting</i>	Acier classe 10/9 <i>Steel A193 Gr B7 / A 194 Gr 2H</i>
4	Siège / Portée d'étanchéité <i>Seat / Tightness-seating</i>	Acier TU 52-b / Stellite Gr 6 <i>Steel A 106 Gr B / Stellite Gr 6</i>
3	Obturateur / Portée d'étanchéité <i>Disc / Tightness-seating</i>	Acier A 42 CP / Stellite Gr 6 <i>Steel A 515 Gr 60 / Stellite Gr 6</i>
2	Chapeau <i>Bonnet</i>	Acier A 480 CP-M <i>Steel A 216 Gr WCB</i>
1	Corps <i>Body</i>	Acier A 480 CP-M <i>Steel A 216 Gr WCB</i>
REP MARK	DESIGNATION DESIGNATION	MATIERE (AFNOR) MATERIAL (ASTM/AISI)

REFERENCES - REFERENCES

Les nuances ASTM/AISI ne figurent qu'à titre indicatif - *ASTM/AISI materials are not contractual*
 Construction - *Construction* : NFE 29.327 (02/85)
 Raccordement - *Connection* : Brides, ISO PN40, type 21-B-FF, NFE 29.203 (07/89)
 Classe de pression - *Pressure class* : ISO PN40
 Essais - *Testing* : NFE 29.311 (06/82), taux d'étanchéité 2
 Courbe pression / TC - *Pressure / TC curve* : NFE 29.005 (91), ISO 7005-1 (04/92)

Robinet 3205-18-DN15

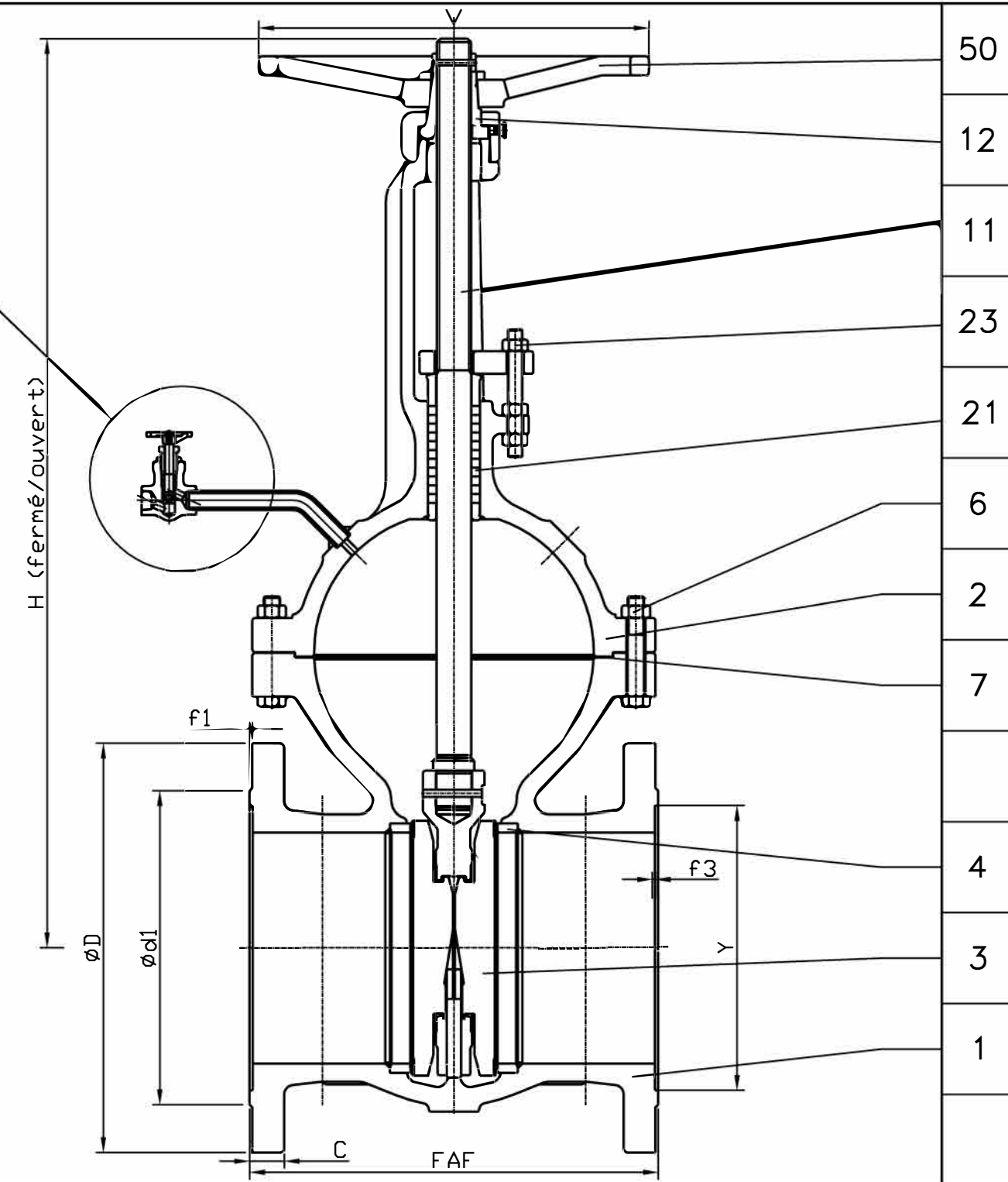

OPTIONS - OPTIONS

DN	200	250							
Catégorie suivant DESP - <i>Type in accordance with PED : 97/23/CE</i>	C3	C3							
FAF mm	425	450							
ØD/C mm	375/34	450/38							
Nbr/ØTrou/ØPerçage <i>Nbr/ØHole/ØDrilling</i>	12/30/320	12/33/385							
Ød1/f1 mm	285/3	345/3							
V mm	400	500							
H (Fermé/Ouvert) <i>(Closed/Opened)</i>	830/1040	995/1260							
Øy/f3	525/250	620/400							
Kv	4340	7040							
Masse - <i>Weight</i>	200	292							

A	118/05/05	A.LAIRAULT	Etablissement du plan		
Indice Index	Date Date	Rédigé Issued by	Vérifié Checked by	Approuvé Approved by	Objet de la modification Modification object
Titre - <i>Title</i>	ROBINET - VANNE "Alpha.S" ISO PN40 A DOUBLE ETANCHEITE CONTROLABLE			Figure - <i>Figure</i>	Orifice - <i>Orifice</i>
				2760 39	200 & 250
Toute reproduction est interdite, sans l'autorisation de SNRI				DEVIS: ELYO Centre ouest 05-16-0171	

