

50	Volant Handwheel	Alpax AS13 Y30 Alpax
23	Boulonnerie du fouloir Gland bolting	Acier classe 10/9 Steel A193 Gr.B7/A194 Gr.2H
21	Garniture Packing	Graphite Graphite
12	Ecrou de tige Stem nut	Fonte FGS Ni22 Cast iron A 439 Gr D-2C
11	Tige Stem	Acier inox Z 20 C13 Stainless steel AISI 420
7	Joint corps/chapeau Body/bonnet gasket	Graphite Graphite
6	Boulonnerie corps/chapeau Body/bonnet bolting	Acier classe 10/9 Steel A193 Gr B7 / A 194 Gr 2H
4	Siège / Portée d'étanchéité Seat / Tightness-seating	Stellite Stellite
3	Obturateur / Portée d'étanchéité Disc / Tightness-seating	Stellite Stellite
2	Chapeau Bonnet	Acier A 48 CP Steel A 105 N
1	Corps Body	Acier A 480 CP-M Steel A 216 Gr WCB
REP MARK	DESIGNATION DESIGNATION	MATIERE (AFNOR) MATERIAL (ASTM/AISI)

REFERENCES - REFERENCES

Les nuances ASTM/AISI ne figurent qu'à titre indicatif - ASTM/AISI materials are not contractual  
 Construction - Construction : NFE 29.327 (02/85)  
 Raccordement - Connection : Brides, ISO PN40, type 21-B, NFE 29.203 (07/89)  
 Classe de pression - Pressure class : ISO PN40  
 Essais - Testing : NFE 29.311 (06/82), taux d'étanchéité 2  
 Courbe pression / TC - Pressure / TC curve : NFE 29.005 (91), ISO 7005-1 (04/92)

OPTIONS - OPTIONS

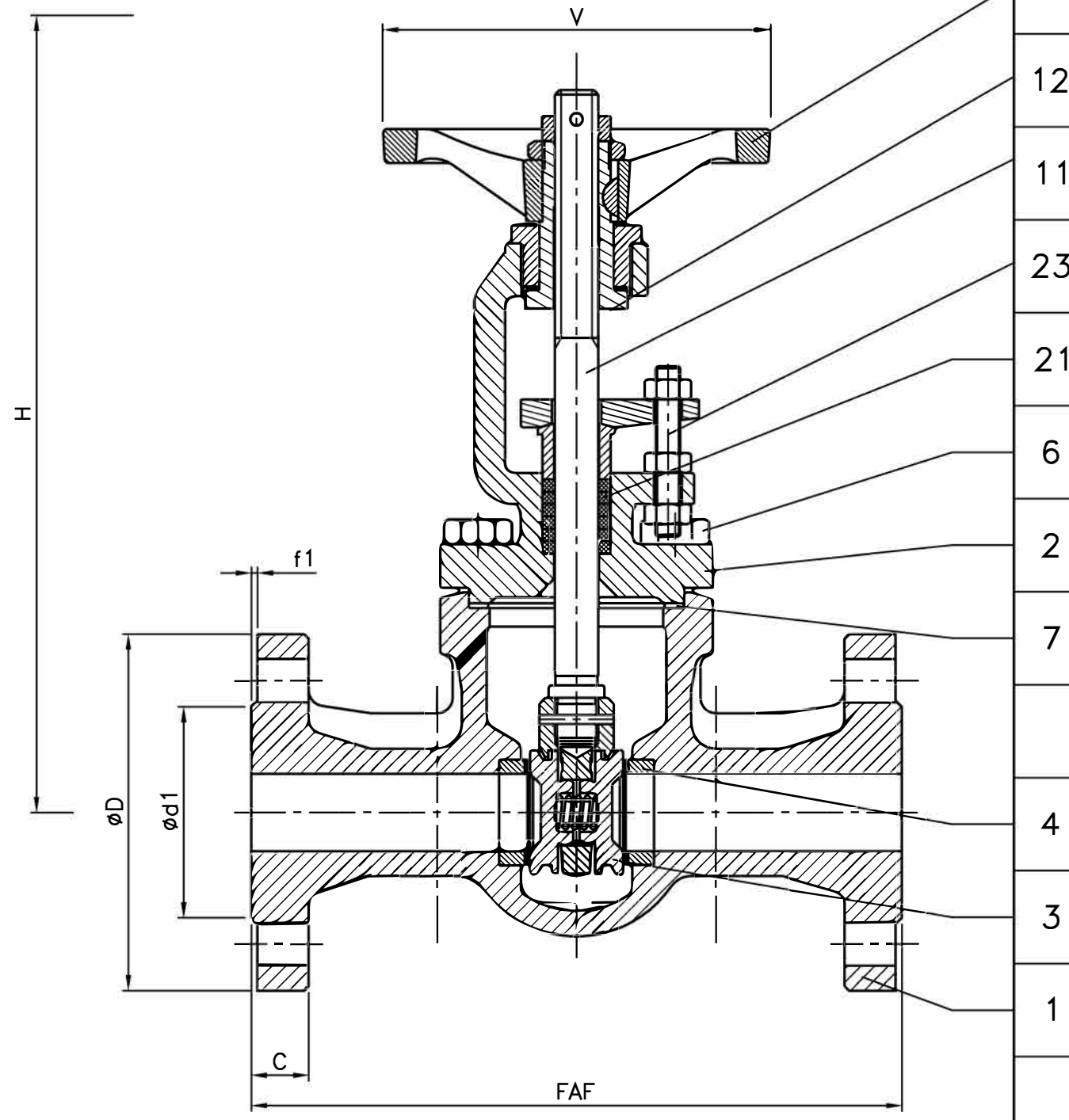

DN	15	20	25	32	40
Catégorie suivant DESP - Type in accordance with PED : 97/23/CE	art.3.3	art.3.3	art.3.3	C2	C2
FAF mm	140	152	210	230	240
øD/C mm	95/16	105/18	115/18	140/18	150/18
Nbr/øTrou/øPerçage Nbr/øHole/øDrilling	4/14/65	4/14/75	4/14/85	4/18/100	4/18/110
ød1/f1 mm	45/2	58/2	68/2	78/2	88/3
V mm	100	100	125	125	160
H (Ouvert) (Opened) mm	210	220	245	265	310
Kv	20	36	57	93	143
Masse - Weight kg	4.3	5.2	7.5	11	13

B	15/11/01	C. Longuet	A. Lairault	D. Dunoyer	Mise à jour du plan suivant DESP 97/23/CE
A	21/09/98	R. Proust			Etablissement du plan
Indice Index	Date Date	Rédigé Issued by	Vérfié Checked by	Approuvé Approved by	Objet de la modification Modification object
Titre-Title	ROBINET-VANNE "Alpha.S" ISO PN40 GATE VALVE			Figure - Figure	Orifice - Orifice
				2760   09	15 à 40
Toute reproduction est interdite, sans l'autorisation de SNRI					-

