

50	Volant Handwheel	Fonte FGS 400/15 Cast iron A 536 Gr 60-40-18
23	Boulonnerie du fouloir Gland bolting	Acier classe 10/9 Steel A193 Gr.B7/A194 Gr.2H
21	Garniture Packing	Graphite Graphite
12	Ecrou de tige Stem nut	Fonte FGS Ni22 Cast iron A 439 Gr D-2C
11	Tige Stem	Acier inox Z 20 C13 Stainless steel AISI 420
7	Joint corps/chapeau Body/bonnet gasket	Graphite Graphite
6	Boulonnerie corps/chapeau Body/bonnet bolting	Acier classe 10/9 Steel A193 Gr.B7/A194 Gr.2H
4	Siège / Portée d'étanchéité Seat / Tightness-seating	Acier TU 52-b / Stellite Gr 6 Steel A 106 Gr B / Stellite Gr 6
3	Obturateur / Portée d'étanchéité Disc / Tightness-seating	Acier A 42 CP / Stellite Gr 6 Steel A 515 Gr 60 / Stellite Gr 6
2	Chapeau Bonnet	Acier A 480 CP-M Steel A 216 Gr WCB
1	Corps Body	Acier A 480 CP-M Steel A 216 Gr WCB

REP MARK	DESIGNATION DESIGNATION	MATIERE (AFNOR) MATERIAL (ASTM/AISI)
-------------	----------------------------	---

REFERENCES - REFERENCES

Les nuances ASTM/AISI ne figurent qu'à titre indicatif - ASTM/AISI materials are not contractual

Construction - Construction : NFE 29.327 (02/85). Face à face ISO PN20

Raccordement - Connection : Embouts à souder BW svt norme NFE 29 032. Forme C2 (8/85)

Classe de pression - Pressure class : ISO PN20

Essais - Testing : NFE 29.311 (06/82), taux d'étanchéité 2

Courbe pression / TC - Pressure / TC curve : NFE 29.005 (91), ISO 7005-1 (04/92)

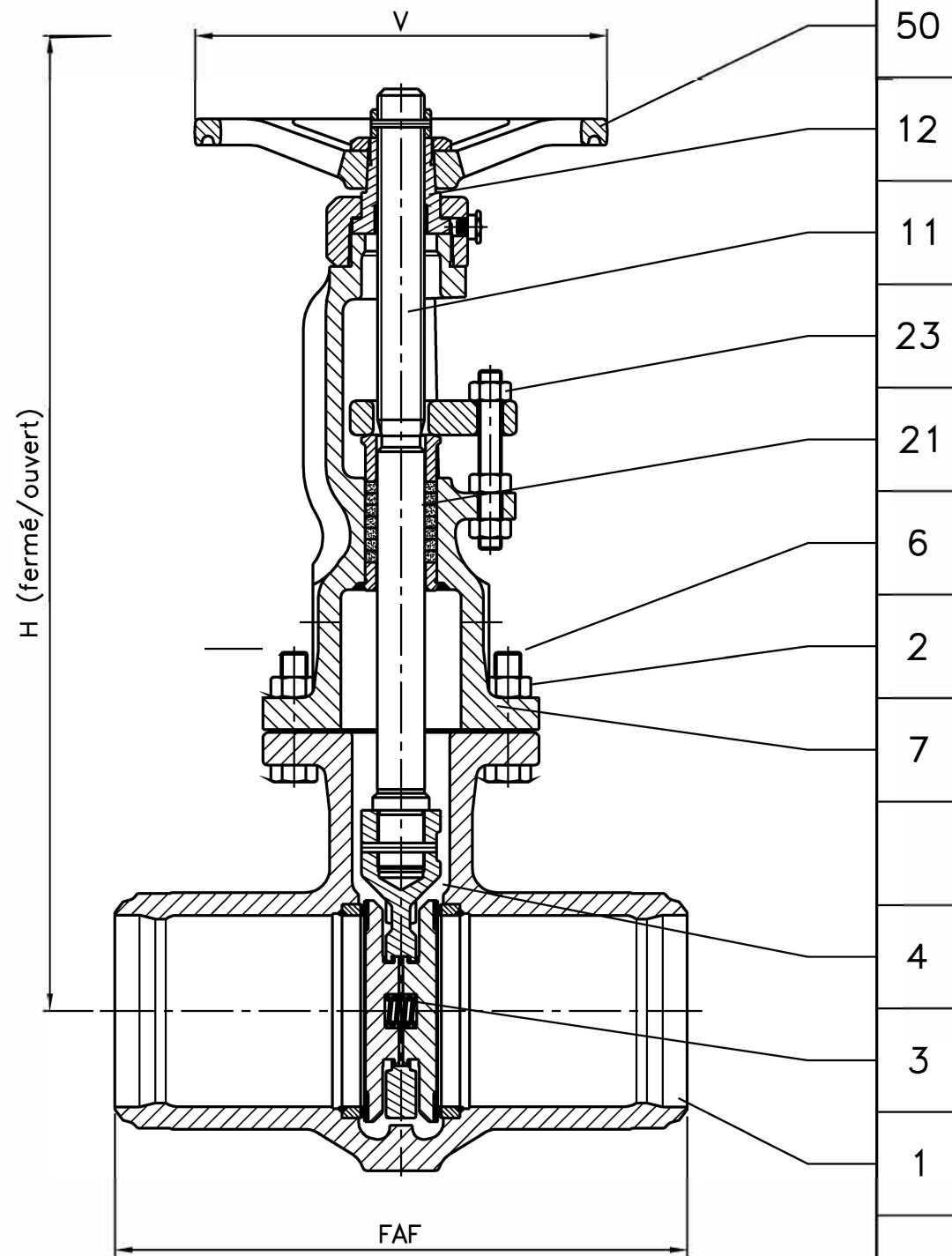
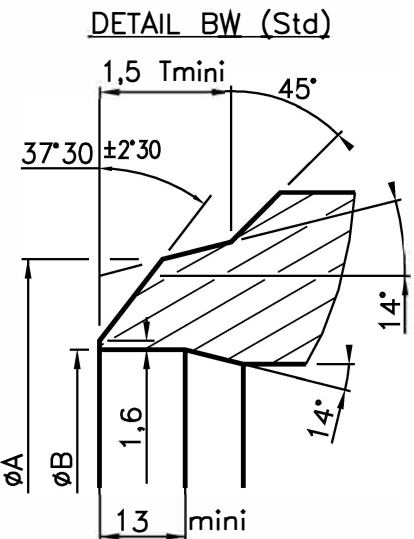

DN	200								
Catégorie suivant DESP - Type in accordance with PED : 97/23/CE	C2								
FAF	mm	419							
ØA	mm	223							
ØB	mm	Selon schédule commande client							
V	mm	315							
H (Fermé/Ouvert) (Closed/Opened)	mm	763/974							
Pression limite cde manuelle		-							
Kv		4350							
Masse - Weight	kg	110							

C	08.02.02	C. Longuet	A. Lairault	D. Dunoyer	Mise à jour du plan (ØA)
B	24.10.01	C. Longuet	A. Lairault	D. Dunoyer	Mise à jour du plan suivant DESP 97/23/CE
A	21/09/98	R. Proust			Etablissement du plan
Indice Index	Date Date	Rédigé Issued by	Vérifié Checked by	Approuvé Approved by	Objet de la modification Modification object

Titre - Title	ROBINET - VANNE "Alpha.S" ISO PN20 GATE VALVE			Figure - Figure	Orifice - Orifice
				2756   09	200

Toute reproduction est interdite, sans l'autorisation de SNRI -