

50	Volant Handwheel	Fonte FGS 400/15 Cast iron A 536 Gr 60-40-18
23	Boulonnerie du fouloir Gland bolting	Acier classe 10/9 Steel A193 Gr.B7/A194 Gr.2H
21	Garniture Packing	Graphite Graphite
12	Ecrou de tige Stem nut	Fonte FGS Ni22 Cast iron A 439 Gr D-2C
11	Tige Stem	Acier inox Z 20 C13 Stainless steel AISI 420
7	Joint corps/chapeau Body/bonnet gasket	Graphite Graphite
6	Boulonnerie corps/chapeau Body/bonnet bolting	Acier classe 10/9 Steel A193 Gr.B7/A194 Gr.2H
4	Siège / Portée d'étanchéité Seat / Tightness-seating	Acier E28.2 / 13% Cr Steel A570 Gr.60 / 13% Cr
3	Obturateur / Portée d'étanchéité Disc / Tightness-seating	Acier A 42 CP / Stellite Gr 6 Steel A 515 Gr 60 / Stellite Gr 6
2	Chapeau Bonnet	Acier A 480 CP-M Steel A 216 Gr WCB
1	Corps Body	Acier A 480 CP-M Steel A 216 Gr WCB
REP MARK	DESIGNATION DESIGNATION	MATIERE (AFNOR) MATERIAL (ASTM/AISI)

REFERENCES - REFERENCES

Les nuances ASTM/AISI ne figurent qu'à titre indicatif - ASTM/AISI materials are not contractual  
 Construction - Construction : NFE 29.327 (02/85)  
 Raccordement - Connection : Brides, ISO PN16, type 21-B, NFE 29.203 (07/89)  
 Classe de pression - Pressure class : ISO PN16  
 Essais - Testing : NFE 29.311 (06/82), taux d'étanchéité 2  
 Courbe pression / TC - Pressure / TC curve : NFE 29.005 (91), ISO 7005-1 (04/92)

OPTIONS - OPTIONS

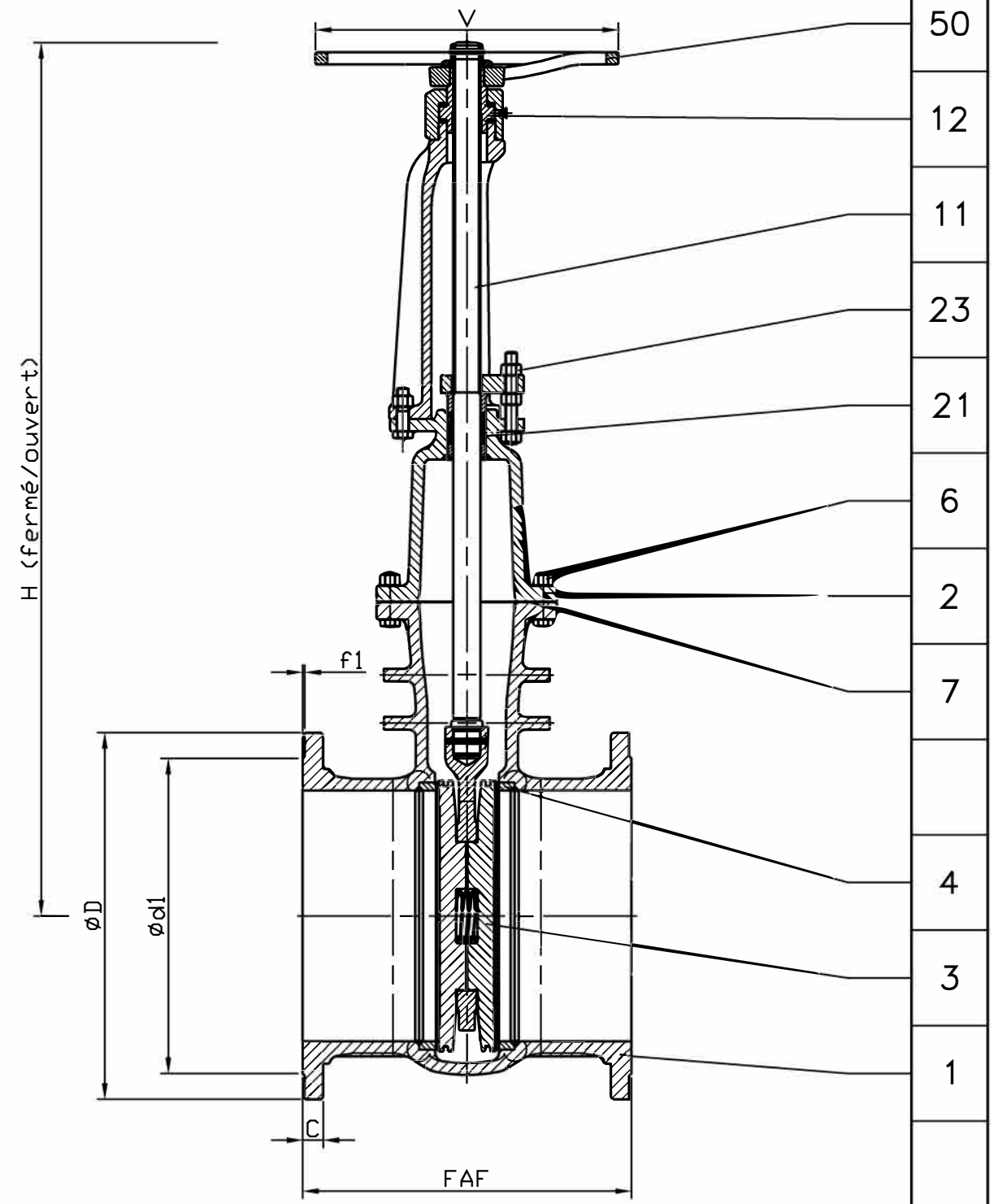

DN	450	500							
Catégorie suivant DESP - Type in accordance with PED : 97/23/CE	C3	C3							
FAF mm	575	625							
ØD/C mm	640/36	715/36							
Nbr/ØTrou/ØPerçage Nbr/ØHole/ØDrilling mm	20/30/585	20/33/650							
Ød1/f1 mm	550/4	610/4							
V mm	600	700							
H (Fermé/Ouvert) (Closed/Opened) mm	1530/1980	1735/2238							
Masse - Weight kg	535	650							

A	05.11.03	C. Longuet	A. Lairault	D. Dunoyer	Etablissement du plan/First issue
Indice Index	Date Date	Rédigé Issued by	Vérfié Checked by	Approuvé Approved by	Objet de la modification Modification object
Titre - Title	ROBINET - VANNE "Alpha.S" ISO PN16 GATE VALVE			Figure - Figure	Orifice - Orifice
				2750   08	450 à 500
Toute reproduction est interdite, sans l'autorisation de SNRI					-

