

50	Volant Handwheel	Fonte FGS 400/15 Cast iron A 536 Gr 60-40-18
23	Boulonnerie du fouloir Gland bolting	Acier classe 10/9 Steel A193 Gr.B7/A194 Gr.2H
21	Garniture Packing	Graphite Graphite
12	Ecrou de tige Stem nut	Acier S 300 Pb Steel A 29 Gr 12 L 14
11	Tige Stem	Acier inox Z8 CF17 Stainless steel AISI 430
7	Joint corps/chapeau Body/bonnet gasket	Graphite Graphite
6	Boulonnerie corps/chapeau Body/bonnet bolting	Acier classe 10/9 Steel A193 Gr.B7/A194 Gr.2H
4	Siège / Portée d'étanchéité Seat / Tightness-seating	Bronze Cu Sn7 Pb6 Zn Bronze B145 Gr 4A
3	Obturateur / Portée d'étanchéité Disc / Tightness-seating	Acier A 42 CP / Cupro-alu Cu Al8 Steel A 515 Gr 60 / Cupro-alu B169 Alloy C
2	Chapeau Bonnet	Fonte FGL 250 Cast Iron A 126 Class B
1	Corps Body	Fonte FGL 250 Cast Iron A 126 Class B
REP MARK	DESIGNATION DESIGNATION	MATIERE (AFNOR) MATERIAL (ASTM/AISI)

REFERENCES - REFERENCES

Les nuances ASTM/AISI ne figurent qu'à titre indicatif - ASTM/AISI materials are not contractual
 Construction - Construction : NFE 29.305 (07/88)
 Raccordement - Connection : Brides ISO PN16, type 21-B, NF-EN 1092-2 (09/97)
 Classe de pression - Pressure class : ISO PN16
 Essais - Testing : NFE 29.311 (06/82), taux d'étanchéité 2
 Courbe pression / TC - Pressure / TC curve : NFE 29.006 (07/83)

OPTIONS - OPTIONS

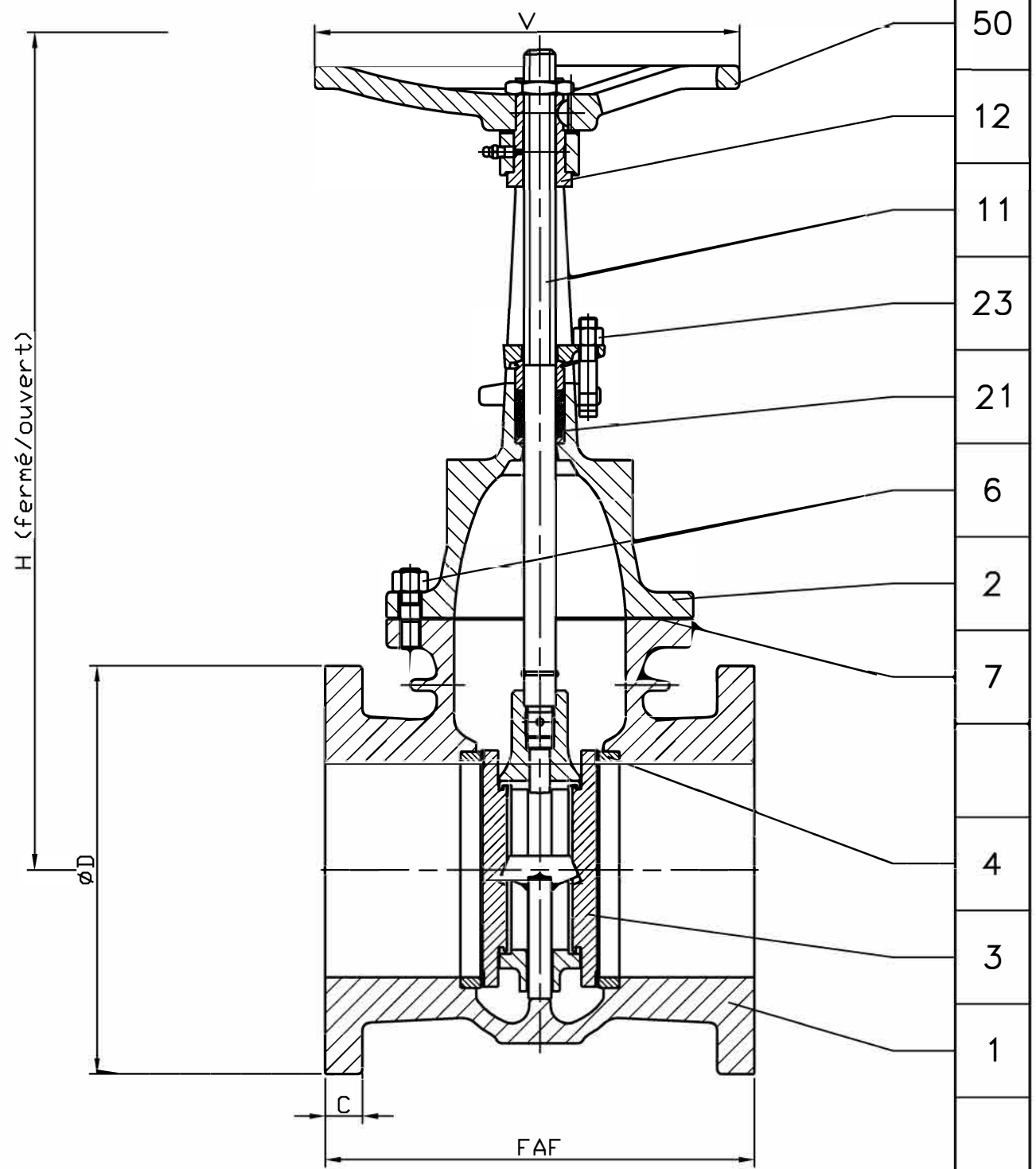

DN	40	50	65	80	100	125	150
Catégorie suivant DESP - Type in accordance with PED : 97/23/CE	art. 3.3	art. 3.3	art. 3.3	art. 3.3	art. 3.3	art. 3.3	art. 3.3
FAF mm	190	200	215	230	250	275	300
ØD/C mm	150/18	165/20	185/20	200/22	220/24	250/26	285/26
Nbr/ØTrou/ØPerçage Nbr/ØHole/ØDrilling	4/19/110	4/19/125	4/19/145	8/19/160	8/19/180	8/19/210	8/23/240
V mm	160	160	200	200	250	315	315
H (Ouvert) (Opened) mm	292	336	385	439	511	612	723
Kv	143	240	260	560	1050	1090	2390
Masse - Weight kg	10.4	15	18	27	39	54	75

A	18.11.03	C. Longuet	A. Lairault	D. Dunoyer	Etablissement du plan/First issue
Indice Index	Date Date	Rédigé Issued by	Vérifié Checked by	Approuvé Approved by	Objet de la modification Modification object
Titre - Title	ROBINET - VANNE "Paraclipex" ISO PN16 GATE VALVE			Figure - Figure	Orifice - Orifice
				2741 31	40 à 150
Toute reproduction est interdite, sans l'autorisation de SNRI					-

