

50	Volant Handwheel	Fonte FGS 400/15 Cast iron A 536 Gr 60-40-18
23	Boulonnerie du fouloir Gland bolting	Acier classe 10/9 Steel A193 Gr.B7/A194 Gr.2H
21	Garniture Packing	Graphite Graphite
12	Ecrou de tige Stem nut	Acier S 300 Pb Steel A 29 Gr 12 L 14
11	Tige Stem	Acier inox Z8 CF17 Stainless steel AISI 430
7	Joint corps/chapeau Body/bonnet gasket	Graphite Graphite
6	Boulonnerie corps/chapeau Body/bonnet bolting	Acier classe 10/9 Steel A193 Gr.B7/A194 Gr.2H
4	Siège / Portée d'étanchéité Seat / Tightness-seating	Bronze Cu Sn7 Pb6 Zn4 Bronze B505 Gr 836
3	Obturateur / Portée d'étanchéité Disc / Tightness-seating	Acier A 42 CP / Cupro-alu Cu Al8 Steel A 515 Gr 60 / Cupro-alu B169 Alloy C
2	Chapeau Bonnet	Fonte FGL 250 Cast Iron A 126 Class B
1	Corps Body	Fonte FGL 250 Cast Iron A 126 Class B
REP MARK	DESIGNATION DESIGNATION	MATIERE (AFNOR) MATERIAL (ASTM/AISI)

REFERENCES - REFERENCES

Les nuances ASTM/AISI ne figurent qu'à titre indicatif - ASTM/AISI materials are not contractual
 Construction - Construction : NFE 29.305 (07/88)
 Raccordement - Connection : Brides ISO PN16, type 21-B, NF-EN 1092-2 (09/97)
 Classe de pression - Pressure class : ISO PN16
 Essais - Testing : NFE 29.311 (06/82), taux d'étanchéité 2
 Courbe pression / TC - Pressure / TC curve : NFE 29.006 (07/83)

OPTIONS - OPTIONS

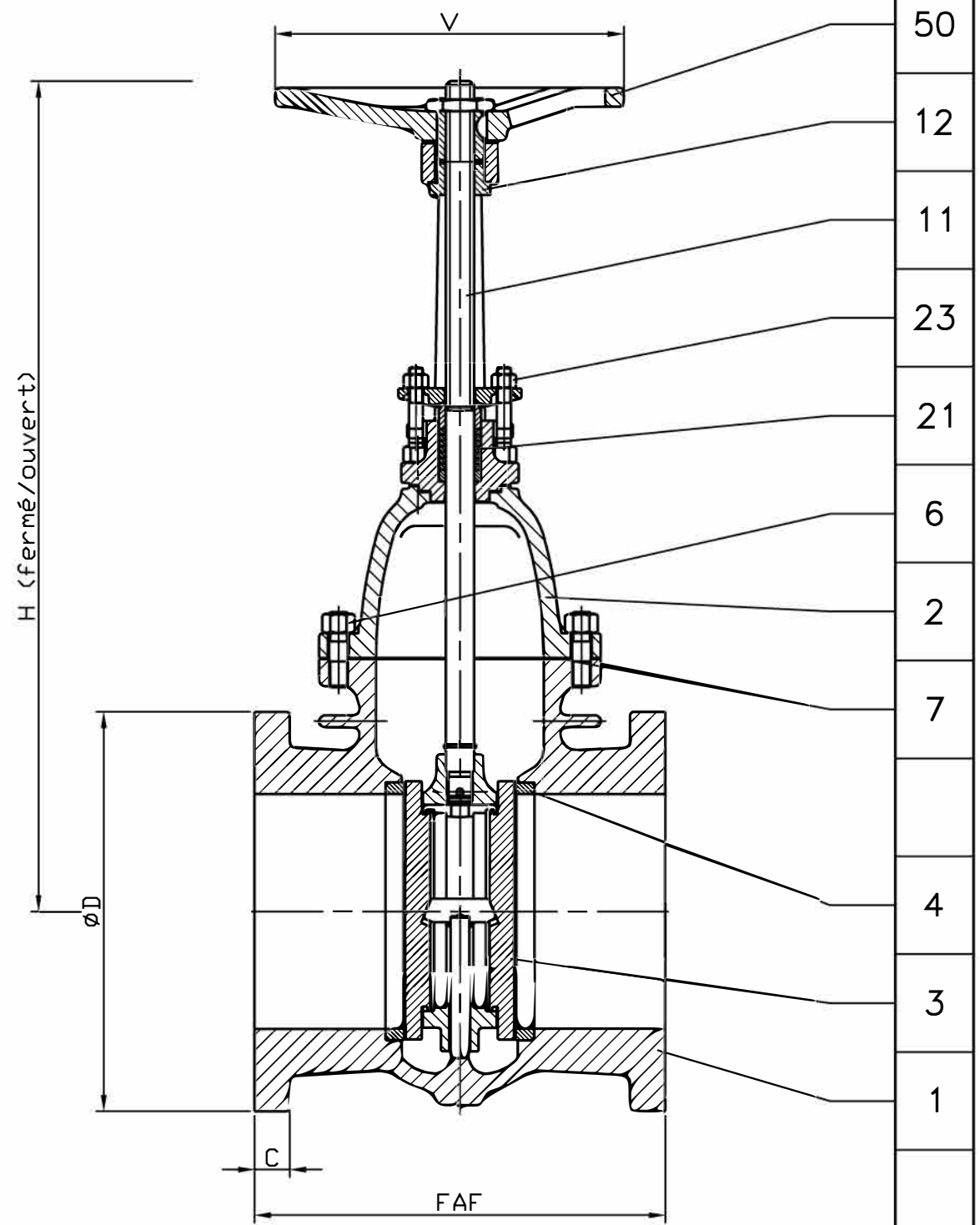

DN	200	250	300	350	400			
Catégorie suivant DESP - Type in accordance with PED : 97/23/CE	art. 3.3	art. 3.3	art. 3.3	C1	C1			
FAF mm	350	400	425	475	525			
ØD/C mm	340/30	405/32	460/32	520/36	580/38			
Nbr/ØTrou/ØPerçage Nbr/ØHole/ØDrilling	12/23/295	12/28/355	12/28/410	16/28/470	16/31/525			
V mm	315	400	400	400	500			
H (Ouvert) (Opened)	916	1112	1303	1496	1713			
Kv	4460	7140	10570	13000	17450			
Masse - Weight	116	192	270	374	510			

A	18.11.03	C. Longuet	A. Lairault	D. Dunoyer	Etablissement du plan/First issue
Indice Index	Date Date	Rédigé Issued by	Vérifié Checked by	Approuvé Approved by	Objet de la modification Modification object
Titre - Title	ROBINET - VANNE "Paraclipex" ISO PN16 GATE VALVE			Figure - Figure	Orifice - Orifice
				2741 31	200 à 400
Toute reproduction est interdite, sans l'autorisation de SNRI					-

