

50	Volant Handwheel	Carbon Steel
23	Boulonnerie du fouloir Gland bolting	Steel A193 Gr B7 / A 194 Gr 2H
21	Garniture Packing	Graphite / Anti-Extrusion
12	Ecrou de tige Stem nut	AISI 416
11	Tige Stem	ASTM A 182 F6
7	Joint corps/chapeau Body/bonnet gasket	Spiral AISI 316 + Graphite
6	Boulonnerie corps/chapeau Body/bonnet bolting	Steel A193 Gr B7 / A 194 Gr 2H
4	Siège / Portée d'étanchéité Seat / Tightness-seating	Steel ASTM A105N / Stellite
3	Obturateur / Portée d'étanchéité Disc / Tightness-seating	ASTM A182 F6 / Stellite
2	Chapeau Bonnet	Steel ASTM A105N
1	Corps Body	Steel ASTM A105N
REP MARK	DESIGNATION DESIGNATION	MATIERE (AFNOR) MATERIAL (ASTM/AISI)

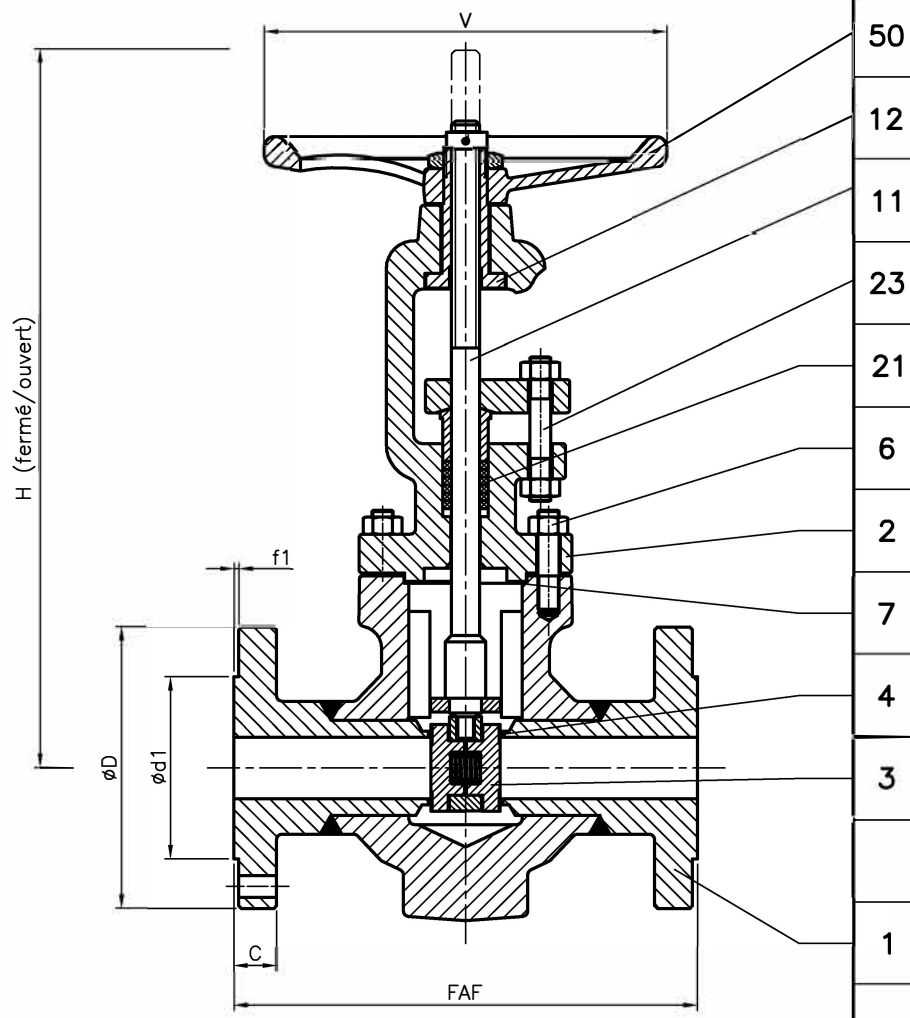

REFERENCES - REFERENCES

Les nuances ASTM/AISI ne figurent qu'à titre indicatif - ASTM/AISI materials are not contractual
 Construction - Construction : NF EN 1984 - ANSI B16.34
 Raccordement - Connection : Brides, ISO PN40, type 21-B, NF EN 1092-1.
 Classe de pression - Pressure class : ISO PN40
 Essais - Testing : NF EN 12266-1, taux de fuite B
 Courbe pression / TC - Pressure / TC curve : NF EN 12516

OPTIONS - OPTIONS



DN	15	20	25	32	40
Catégorie suivant DESP - Type in accordance with PED : 97/23/CE	art.3.3	art.3.3	art.3.3	C2	C2
FAF mm	140	152	210	230	240
øD/C mm	95/16	105/18	115/18	140/18	150/18
Nbr/øTrou/øPerçage Nbr/øHole/øDrilling mm	4/14/65	4/14/75	4/14/85	4/18/100	4/18/110
ød1/f1 mm	45/2	58/2	68/2	78/2	88/3
V mm	160	160	160	160	220
H (Fermé/Ouvert) (Closed/Opened) mm	188/205	188/207	270/296	270/298	318/358
Kv	20	36	57	93	143
Masse - Weight kg	6	8	13	16	24

A	01/09/15	A.Mousnier	J. RODHAIN	Etablissement du plan	
Indice Index	Date	Rédigé Issued by	Vérfié Checked by	Approuvé Approved by	Objet de la modification Modification object
Titre - Title	ROBINET-VANNE "Alpha.S" ISO PN40 GATE VALVE			Figure - Figure	Orifice - Orifice
				0760 49	15 à 40
Toute reproduction est interdite, sans l'autorisation de SNRI					-
 SNRI			 Robival GROUPE ROBINETTERIE INDUSTRIELLE ET INSTRUMENTATION		