

50	Volant Handwheel	Alpax AS13 Y30 Alpax
23	Boulonnerie du fouloir Gland bolting	Acier classe 10/9 Steel A193 Gr.B7/A194 Gr.2H
21	Garniture Packing	Graphite Graphite
12	Ecrou de tige Stem nut	Acier S 300 Pb Steel A 29 Gr 12 L 14
11	Tige Stem	Acier inox Z2 CND17.12 Stainless steel AISI 316 L
7	Joint corps/chapeau Body/bonnet gasket	Graphite Graphite
6	Boulonnerie corps/chapeau Body/bonnet bolting	Acier classe 10/9 Steel A193 Gr.B7/A194 Gr.2H
4	Siège / Portée d'étanchéité Seat / Tightness-seating	Acier inox Z2 CND17.12 Stainless steel AISI 316 L
3	Obturateur / Portée d'étanchéité Disc / Tightness-seating	Acier inox Z2 CND18.12M Stainless steel A351 Gr. CF3M
2	Chapeau Bonnet	Acier A 480 CP-M Steel A 216 Gr WCB
1	Corps Body	Acier A 480 CP-M Steel A 216 Gr WCB
REP MARK	DESIGNATION DESIGNATION	MATIERE (AFNOR) MATERIAL (ASTM/AISI)

REFERENCES - REFERENCES

Les nuances ASTM/AISI ne figurent qu'à titre indicatif - ASTM/AISI materials are not contractual
 Construction - Construction : NFE 29.327 (02/85)
 Raccordement - Connection : Brides, ISO PN16, type 21-B, NFE 29.203 (07/89)
 Classe de pression - Pressure class : ISO PN16
 Essais - Testing : NFE 29.311 (06/82), taux d'étanchéité 2
 Courbe pression / TC - Pressure / TC curve : NFE 29.005 (91), ISO 7005-1 (04/92)

OPTIONS - OPTIONS

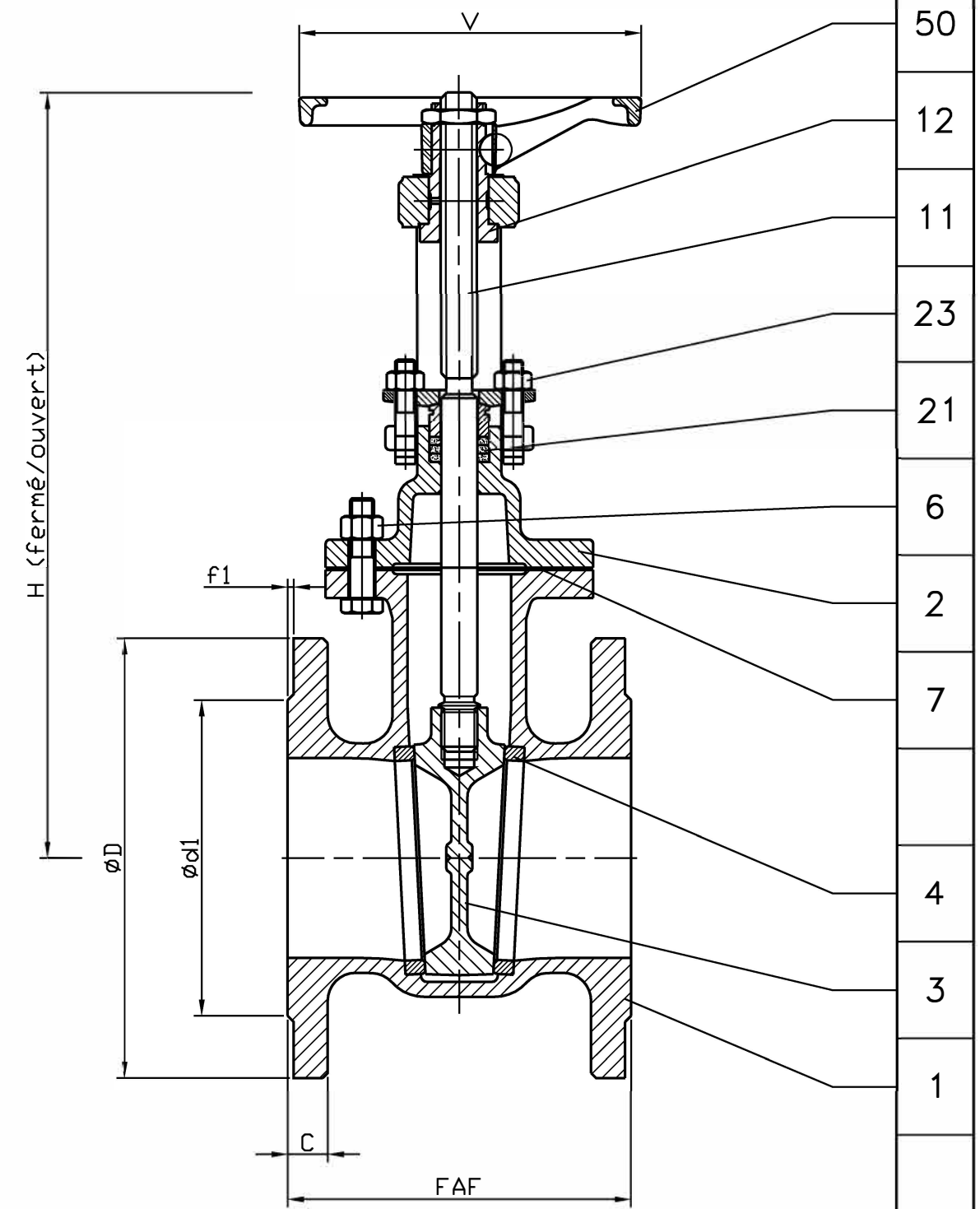

DN	80	100							
Catégorie suivant DESP - Type in accordance with PED : 97/23/CE	C2	C2							
FAF mm	160	172							
ØD/C mm	200/20	220/20							
Nbr/ØTrou/ØPerçage Nbr/ØHole/ØDrilling	8/18/160	8/18/180							
Ød1/f1 mm	138/3	158/3							
V mm	160	160							
H (Ouvert) (Opened) mm	404	492							
Kv	660	1060							
Masse - Weight kg	19.5	24.5							

A	05.11.03	C. Longuet	A. Lairault	D. Dunoyer	Etablissement du plan/First issue
Indice Index	Date Date	Rédigé Issued by	Vérifié Checked by	Approuvé Approved by	Objet de la modification Modification object
Titre-Title	ROBINET-VANNE "Stilclip" ISO PN16 GATE VALVE			Figure - Figure	Orifice - Orifice
				2745 87	40 à 150
Toute reproduction est interdite, sans l'autorisation de SNRI					-

