

50	Volant <i>Handwheel</i>	Alpax <i>Alpax</i>
11	Tige <i>Stem</i>	Acier inox Z 20 C13 <i>Stainless steel AISI 420</i>
7	Joint corps/chapeau <i>Body/bonnet gasket</i>	Nitrile 90S <i>Nitrile 90S</i>
6	Boulonnerie corps/chapeau <i>Body/bonnet bolting</i>	Acier classe 10/9 <i>Steel A193 Gr.B7/A194 Gr.2H</i>
4	Siège <i>Seat</i>	Fonte FGL 250 <i>Cast Iron A 126 Class B</i>
3	Obturateur <i>Disc</i>	Bronze Cu Sn5 Pb5 Zn5 <i>Bronze B145 Gr 4A</i>
2	Chapeau <i>Bonnet</i>	Fonte FGL 250 <i>Cast Iron A 126 Class B</i>
1	Corps <i>Body</i>	Fonte FGL 250 <i>Cast Iron A 126 Class B</i>
REP MARK	DESIGNATION <i>DESIGNATION</i>	MATIERE (AFNOR) <i>MATERIAL (ASTM/AISI)</i>

REFERENCES - REFERENCES

Les nuances ASTM/AISI ne figurent qu'à titre indicatif - *ASTM/AISI materials are not contractual*
 Construction - *Construction* : NFE 29.323 (02/85), Serie FR5 ISO PN10
 Raccordement - *Connection* : Brides ISO PN10, type 21, NF-EN 1092-2 (09/97)
 Classe de pression - *Pressure class* : ISO PN10
 Essais - *Testing* : NFE 29.311 (06/82), taux d'étanchéité 2
 Courbe pression / TC - *Pressure / TC curve* : NFE 29.006 (07/83)

OPTIONS - OPTIONS

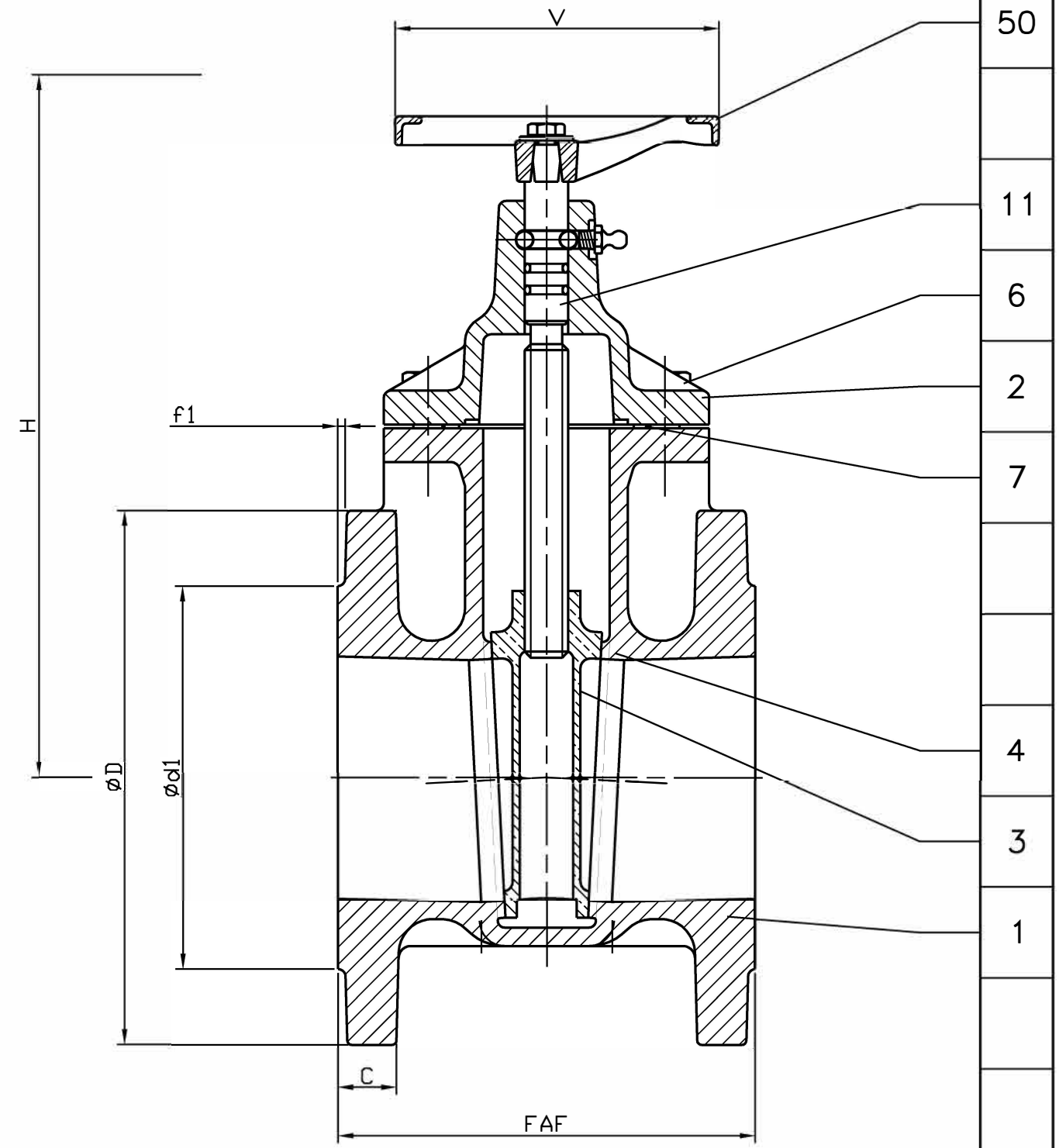

DN	40	50	65	80	100	125	150
Catégorie suivant DESP - <i>Type in accordance with PED : 97/23/CE</i>	art. 3.3	art. 3.3	art. 3.3	art. 3.3	art. 3.3	art. 3.3	art. 3.3
FAF mm	136	142	154	160	172	186	200
øD/C mm	150/18	165/20	185/20	200/22	220/24	250/26	285/26
Nbr/øTrou/øPerçage <i>Nbr/øHole/øDrilling</i>	4/19/110	4/19/125	4/19/145	8/19/160	8/19/180	8/19/210	8/23/240
ød1/f1 mm	84/3	99/3	118/3	132/3	156/3	184/3	211/3
V mm	80	100	100	125	125	125	160
H mm	150	180	215	245	273	315	360
Kv	143	245	430	660	1060	1680	2460
Masse - <i>Weight</i> kg	6,2	8,7	11,5	14,7	19,1	28	36

A	03.06.03	C. Longuet	A. Lairault	D. Dunoyer	Etablissement du plan/First issue
Indice Index	Date Date	Rédigé Issued by	Vérifié Checked by	Approuvé Approved by	Objet de la modification Modification object
Titre - <i>Title</i>	ROBINET - VANNE "CALOCLIP" ISO PN10 GATE VALVE			Figure - <i>Figure</i>	Orifice - <i>Orifice</i>
				2719 00	40 à 150
Toute reproduction est interdite, sans l'autorisation de SNRI					-

