

50	Volant Handwheel	Alpax Alpax
23	Boulonnerie du fouloir Gland bolting	Acier classe 10/9 Steel A193 Gr.B7/A194 Gr.2H
21	Garniture Packing	Graphite Graphite
11	Tige Stem	Acier S300 Pb Steel A29 Gr.12L14
7	Joint corps/chapeau Body/bonnet gasket	Graphite Graphite
6	Boulonnerie corps/chapeau Body/bonnet bolting	Acier 42CD4 Steel A193 Gr.B7/A194 Gr.2H
4	Siège Seat	Fonte FGL 250 Cast Iron A 126 Class B
3	Obturateur Disc	Fonte FGL 250 Cast Iron A 126 Class B
2	Chapeau Bonnet	Fonte FGL 250 Cast Iron A 126 Class B
1	Corps Body	Fonte FGL 250 Cast Iron A 126 Class B
REP MARK	DESIGNATION DESIGNATION	MATIERE (AFNOR) MATERIAL (ASTM/AISI)

REFERENCES - REFERENCES

Les nuances ASTM/AISI ne figurent qu'à titre indicatif - *ASTM/AISI materials are not contractual*
 Construction - *Construction* : -
 Raccordement - *Connection* : Manchons taraudés gaz suivant NFE 03.005 (12/81)
 Classe de pression - *Pressure class* : ISO PN10
 Essais - *Testing* : NFE 29.311 (06/82), taux d'étanchéité 2
 Courbe pression / TC - *Pressure / TC curve* : NFE 29.006 (07/83)

OPTIONS - OPTIONS

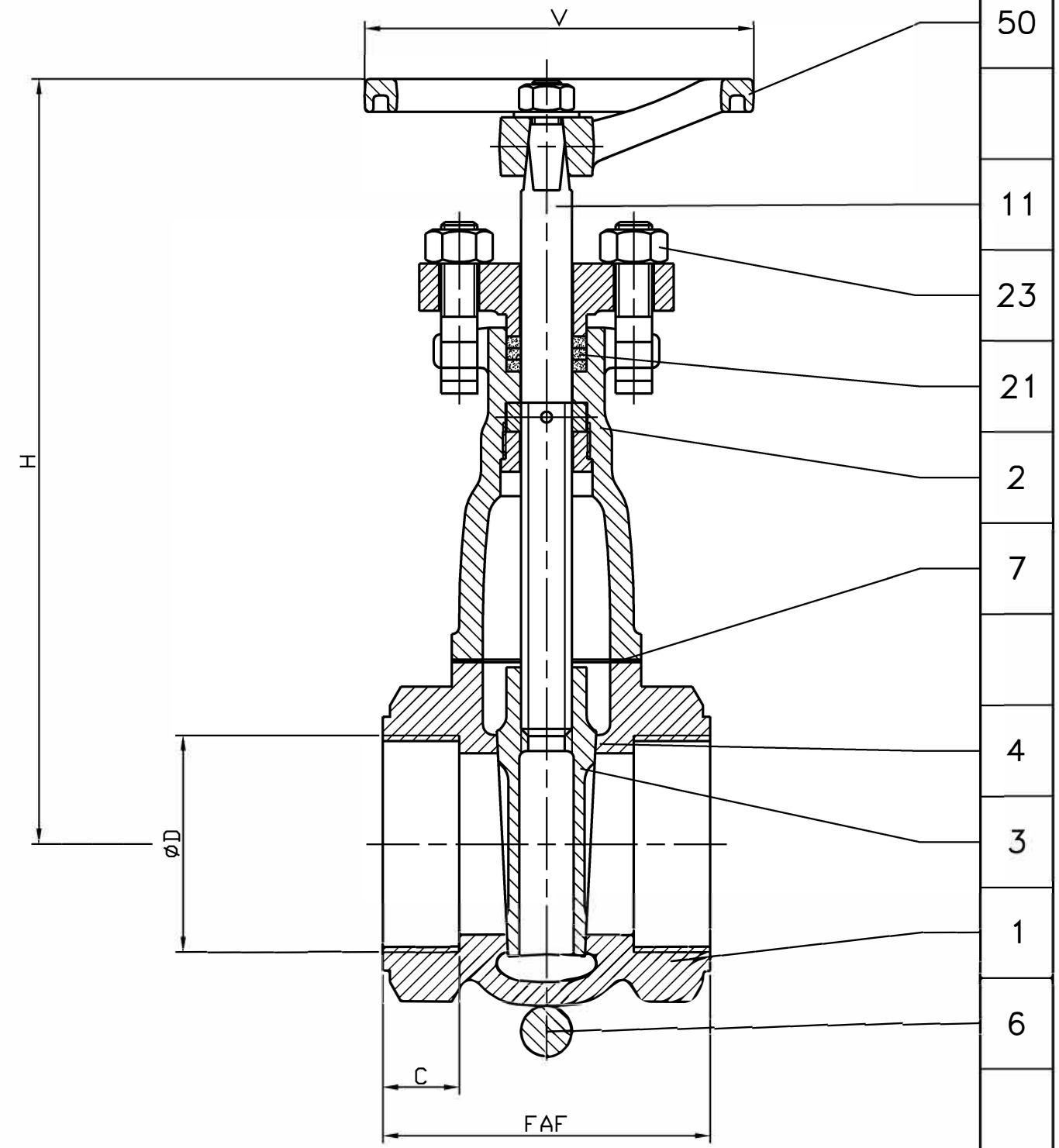

DN	15	20	25	32	40	50
Catégorie suivant DESP - <i>Type in accordance with PED : 97/23/CE</i>	art. 3.3	art. 3.3	art. 3.3	art. 3.3	art. 3.3	art. 3.3
FAF mm	58	63	70	75	85	90
ØD mm	15x21	20x27	26x34	33x42	40x49	50x60
C mm	13	15	17	18	20	21
V mm	63	63	80	80	80	100
H mm	121	132	143	166	177	211
Kv	-	-	-	-	-	-
Masse - <i>Weight</i> kg	0,9	1,1	1,5	2	3	4,2

A	24.02.03	C. Longuet	A. Lairault	D. Dunoyer	Etablissement du plan/First issue
Indice Index	Date Date	Rédigé Issued by	Vérifié Checked by	Approuvé Approved by	Objet de la modification Modification object
Titre - <i>Title</i>	ROBINET - VANNE "SERGOCLIP" ISO PN10 GATE VALVE			Figure - <i>Figure</i>	Orifice - <i>Orifice</i>
				2718 05	15 à 50
Toute reproduction est interdite, sans l'autorisation de SNRI					-

