

50	Volant Handwheel	Fonte FGS 400/1 5 Cast iron A 536 Gr 60-40-18
23	Boulonnerie du fouloir Gland bolting	Acier classe 10/9 Steel A 193 Gr B7 / A 194 Gr 2H
21	Garniture Packing	Graphite Graphite
11	Tige Stem	Acier inox Z 20 C13 Stainless steel AISI 420
7	Joint corps/chapeau Body/bonnet gasket	Spiralé inox graphite Stainless steel graphite spiraled
6	Boulonnerie corps/chapeau Body/bonnet bolting	Acier classe 10/9 Steel A 193 Gr B7 / A 194 Gr 2H
4	Siège / Portée d'étanchéité Seat / Tightness-seating	Acier A 480 CP-M / Stellite Steel A 216 Gr WCB / Stellite
3	Obturateur / Portée d'étanchéité Disc / Tightness-seating	Acier XC 18 S / Stellite Steel A 105 / Stellite
2	Chapeau Bonnet	Acier A 480 CP-M Steel A 216 Gr WCB
1	Corps Body	Acier A 480 CP-M Steel A 216 Gr WCB
MARK	DESIGNATION	MATERIAL (ASTM/AISI)

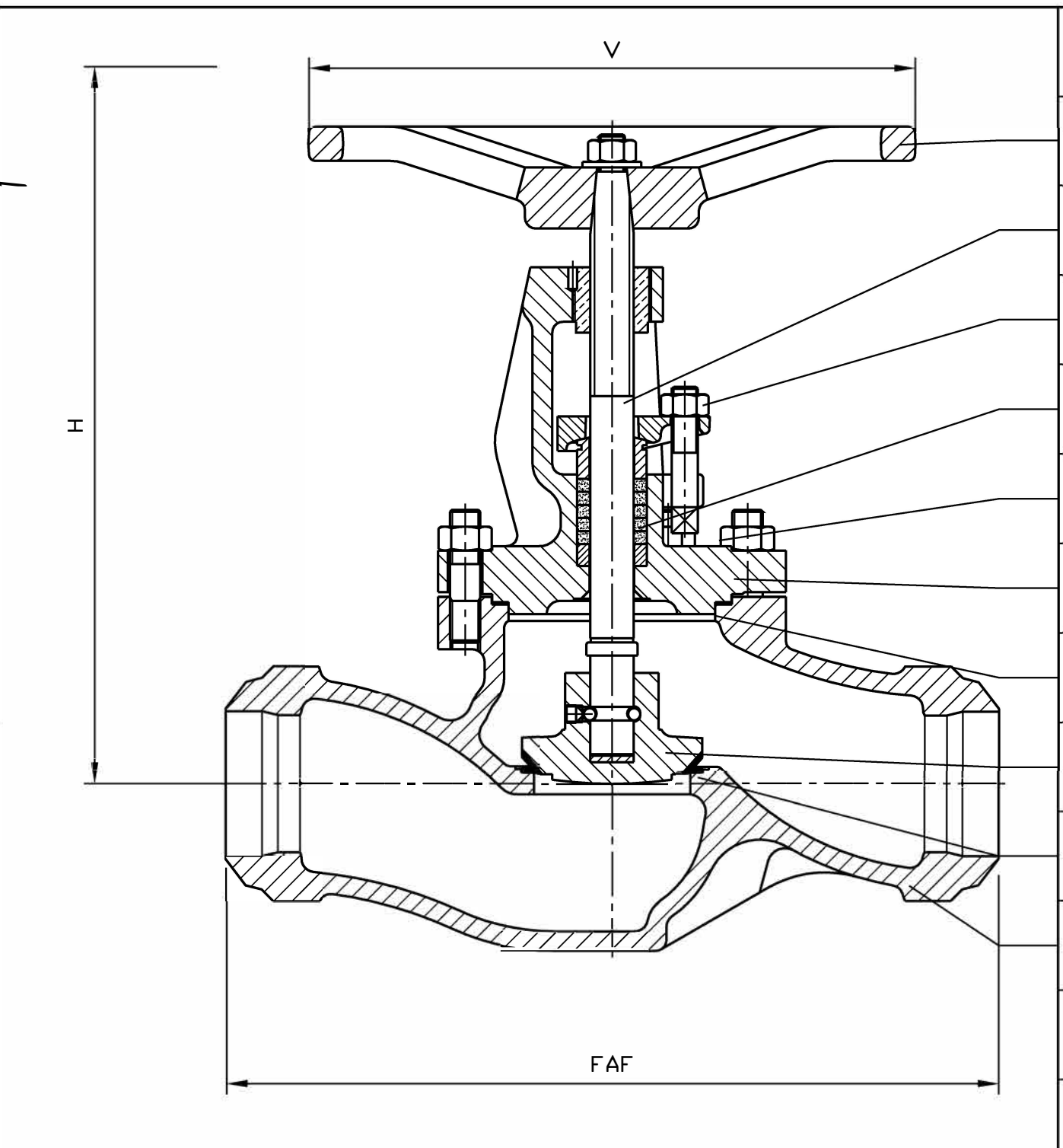
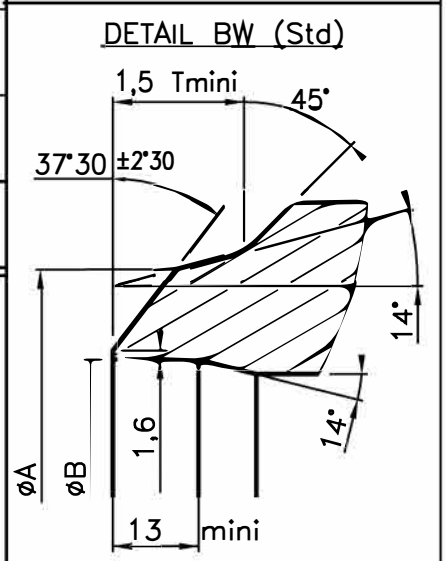
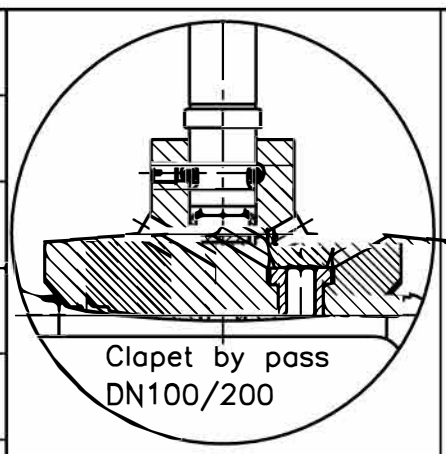

50
11
23
21
6
2
7
3
4
1

REFERENCES - REFERENCES

Les nuances ASTM/AISI ne figurent qu'à titre indicatif - ASTM/AISI materials are not contractual
 Construction - Construction : NFE 29.350 (06/87)
 Raccordement - Connection : Embouts à souder BW svt norme NFE 29-032. Forme C 2.2 (aout 85)
 Classe de pression - Pressure class : ISO PN 100
 Essais - Testing : NFE 29.311 (06/82), taux d'étanchéité 2
 Courbe pression / TC - Pressure / TC curve : NFE 29.005 (91), ISO 7005-1 (04/92)

DN	65	80	100	125	150	200
Catégorie suivant DESP - Type in accordance with PED : 97/23/CE	C2	C2	C2	C3	C3	C3
FAF mm	330	356	432	508	559	660
ØA mm	77	91	117	144	172	223
ØB mm	Selon schédule commande client					
V mm	250	315	315	400	500	500
H (Opened) mm	280	320	347	416	497	593
Kv	80	120	180	285	420	755
Weight kg	17	22	38	58	88	181

C	25/05/05	A.Valentin	A. Lairault	D. Dunoyer	Mise à jour joint spiralé inox graph.(graph.).
B	22.05.02	C. Longuet	A. Lairault	D. Dunoyer	Mise à jour du plan suivant DESP 97/23/CE
A	18/09/01	C.GIRE			Etablissement du plan
Index	Date	Issued by	Checked by	Approved by	Modification object

Title	ROBINET A SOUPAPE "Sergostop" ISO PN 100 GLOBE VALVE			Figure	3199 19	Orifice	65 à 200
-------	--	--	--	--------	-----------	---------	----------

Toute reproduction est interdite, sans l'autorisation de SNRI

