

50	Volant Handwheel	Fonte FGS 400-15 Cast Iron A 536 Gr 60.40.18
23	Boulonnerie du fouloir Gland bolting	Acier classe 10/9 Steel A 193 Gr.B7 / A 194 Gr.2H
11	Tige Stem	Acier Inox Z20 C 13 Stainless Steel A 182 F6
3	Obturateur/Portage (DN 250-300) Disc/Disc face (DN 250-300)	Acier AF42-2/ Stellite Steel AISI 1020 / Stellite
3	Obturateur/Portage (DN 200) Disc/Disc face (DN 200)	Acier A 42 CP / Stellite Steel A 515 Gr 60 / Stellite
4	Siege/Portage Seat/Seating face	Acier AF42-2/ Stellite Steel AISI 1020 / Stellite
21	Garniture d'étancheité Packing	Graphite Graphite
6	Boulonnerie corps/chapeau Body/bonnet bolting	Acier Classe 10/9 Steel A 193 Gr.B7 / A 194 Gr.2H
7	Joint corps/chapeau Body/bonnet gasket	Graphite Graphite
2	Chapeau DN 250-300 Bonnet ND 250-300	Acier A 48 CP Steel A 515 Gr 70
2	Chapeau DN 200 Bonnet ND 200	Acier A 480 CP-M Steel A 216 WCB
1	Corps Body	Acier A 480 CP-M Steel A 216 WCB
REP MARK	DESIGNATION DESIGNATION	MATIERE (AFNOR) MATERIAL (ASTM/AISI)

REFERENCES - REFERENCES

Les nuances ASTM/AISI ne figurent qu'à titre indicatif - ASTM/AISI materials are not contractual  
 Construction - Construction : NFE 29350 (Juin 87)  
 Raccordement - Connection : Brides, ISO PN25/40, type 21-B, NFE 29.203 (07/89)  
 Classe de pression - Pressure class : ISO PN25/40  
 Essais - Testing : NFE 29.311 (06/82), taux d'étanchéité 2  
 Courbe pression / TC - Pressure / TC curve : NFE 29.005 (91), ISO 7005-1 (04/92)

OPTIONS - OPTIONS

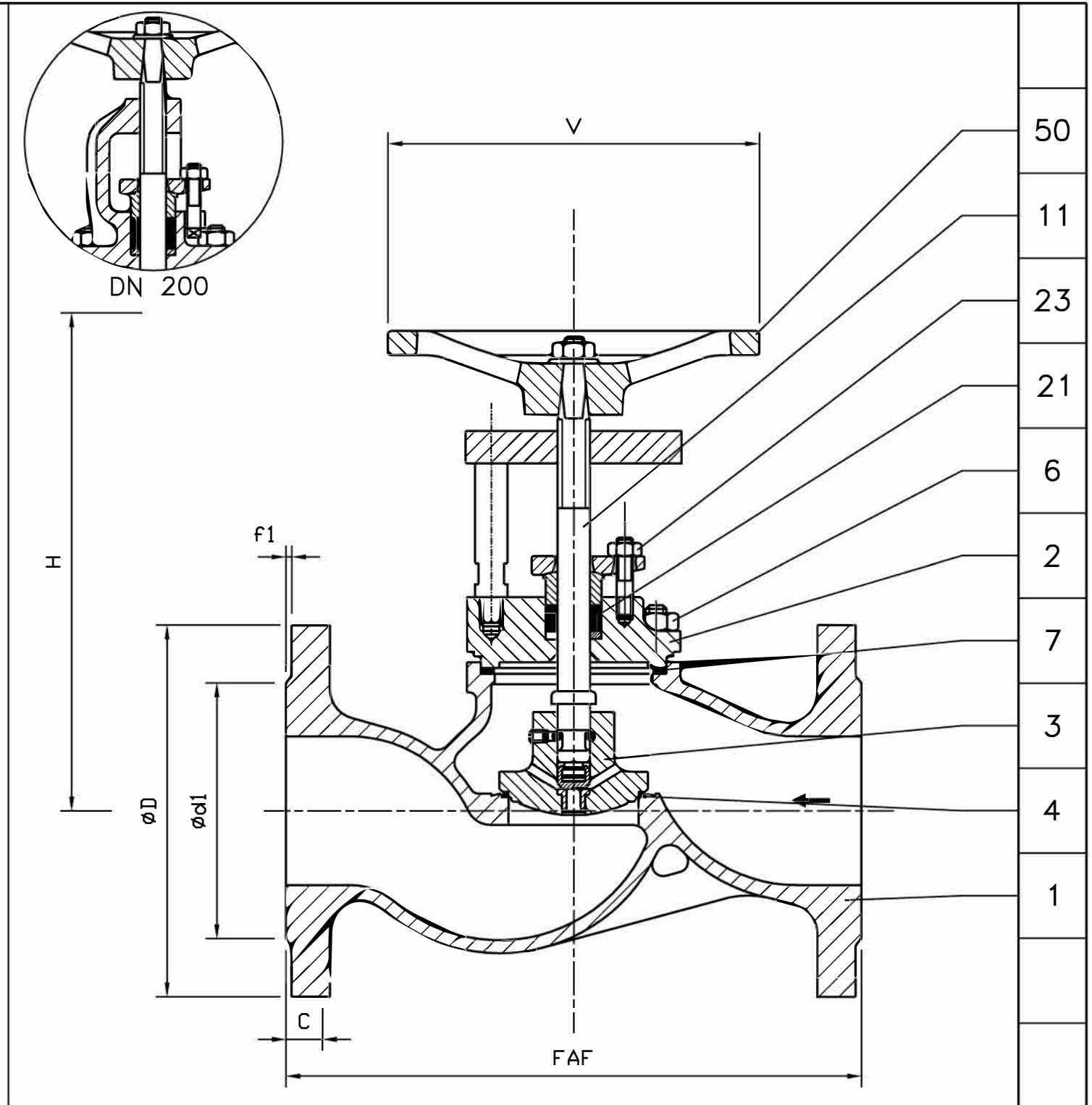

DN	200	250	300					
Catégorie suivant DESP - Type in accordance with PED : 97/23/CE	C3	C3	C3					
FAF mm	600	730	850					
øD / C mm	375/32	450/38	515/42					
Nbr. øTrou. øPerçage / Nbr. øHole. øDrilling mm	12/30/320	12/33/385	16/33/450					
ød1 / f1 mm	285/3	345/3	410/4					
V mm	400	500	630					
H (Ouvert) (Opened) mm	486	577	695					
KV	755	1210	-					
Masse - Weight kg	137	218	346					

B	21.05.02	C. Longuet	A. Lairault	D. Dunoyer	Mise à jour du plan suivant DESP 97/23/CE
A	12/02/01	C.GIRE			Etablissement du plan
Indice Index	Date Date	Rédigé Issued by	Vérifié Checked by	Approuvé Approved by	Objet de la modification Modification object
Titre-Title	ROBINET A SOUPAPE "Sergostop" ISO PN25/40 GLOBE VALVE			Figure - Figure	Orifice - Orifice
				3196   09	200 à 300
Toute reproduction est interdite, sans l'autorisation de SNRI					-

