

50	Volant Handwheel	Alpax Alpax
23	Boulonnerie du fouloir Gland bolting	Acier classe 10/9 Steel A 193 Gr B7 / A 194 Gr 2H
11	Tige Stem	Acier inox Z 20 C13 Stainless steel AISI 420
3	Obturateur / Portée d'étanchéité Disc / Tightness-seating	Acier inox Z 33 C13 Stainless steel AISI 420
4	Siège / Portée d'étanchéité Seat / Tightness-seating	Acier inox Z 8 CF17 Stainless steel AISI 430
21	Garniture Packing	Graphite Graphite
6	Boulonnerie corps/chapeau Body/bonnet bolting	Acier classe 10/9 Steel A 193 Gr B7 / A 194 Gr 2H
7	Joint corps/chapeau Body/bonnet gasket	Graphite Graphite
2	Chapeau Bonnet	Acier A 48 CP Steel A 105N
1	Corps Body	Acier A 480 CP-M Steel A 216 Gr WCB

REP MARK	DESIGNATION DESIGNATION	MATIERE (AFNOR) MATERIAL (ASTM/AISI)
-------------	----------------------------	---

REFERENCES - REFERENCES

Les nuances ASTM/AISI ne figurent qu'à titre indicatif - *ASTM/AISI materials are not contractual*
 Construction - *Construction* : NFE 29.350 (06/87)
 Raccordement - *Connection* : Brides, ISO PN50, Type 21-B1, NFE 29.203 (07/89)
 Classe de pression - *Pressure class* : ISO PN50
 Essais - *Testing* : NFE 29.311 (06/82), taux d'étanchéité 2
 Courbe pression / TC - *Pressure / TC curve* : NFE 29.005 (91), ISO 7005-1 (04/92)

OPTIONS - OPTIONS

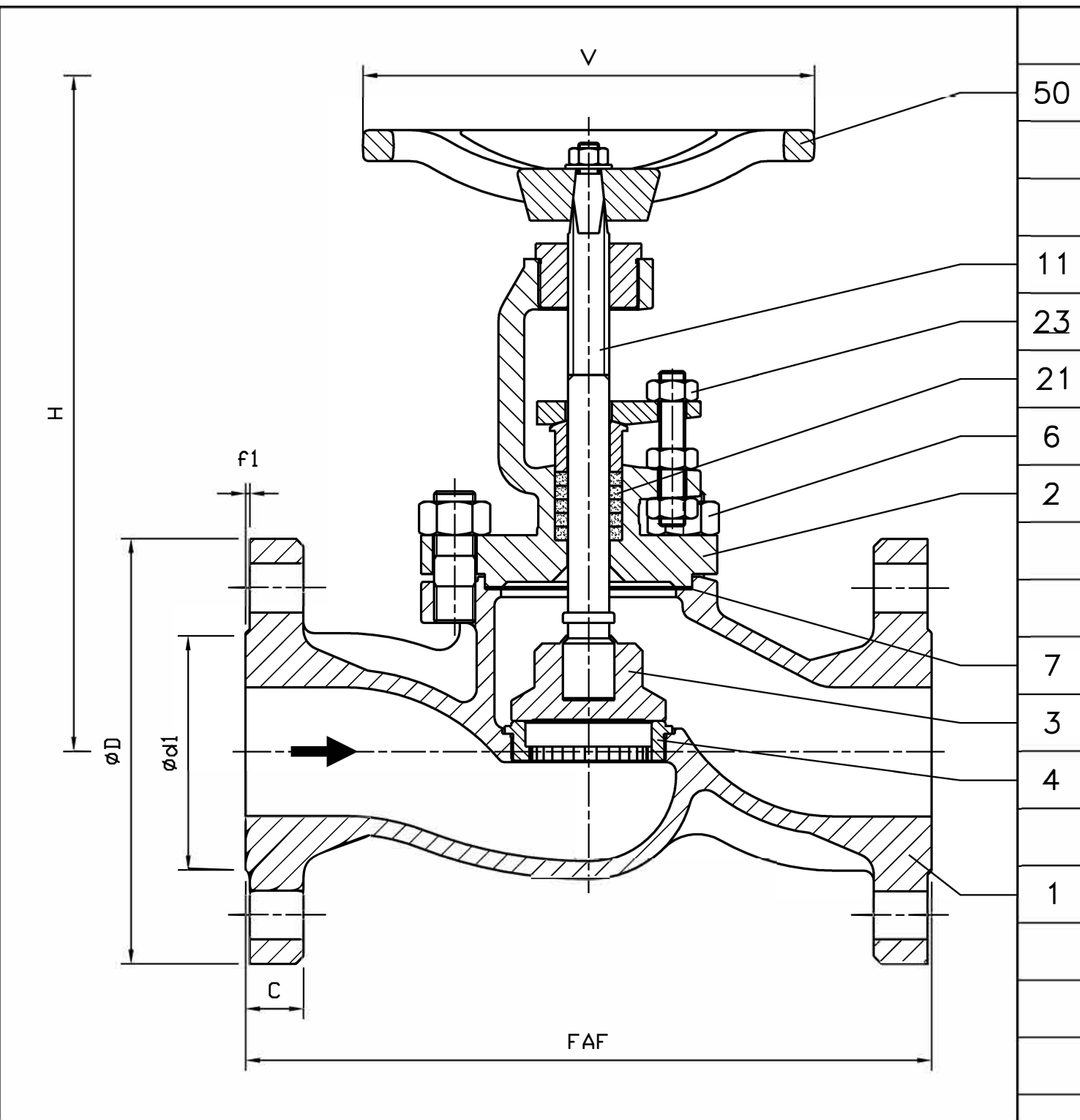

DN	15	20	25	32	40	50
Catégorie suivant DESP - Type in accordance with PED : 97/23/CE	art. 3.3	art. 3.3	art. 3.3	C2	C2	C2
FAF mm	152	178	203	216	229	267
øD/C mm	95/14,2	117/15,7	124/17,5	133/19	156/20,6	165/22,4
Nbr/øTrou/øPerçage Nbr/øHole/øDrilling	4/15,8/66,7	4/19/82,6	4/19/88,9	4/19/98,4	4/22,2/114,3	8/19/127
ød1/f1 mm	34,9/1,6	42,9/1,6	50,8/1,6	63,5/1,6	73/1,6	92,1/1,6
V mm	100	100	125	125	160	160
H (Ouvert) (Opened) mm	190	190	223	223	257	257
Kv	4,9	6,9	11,2	18	38	45
Masse - Weight kg	3,1	5,2	8,1	10	12,6	15,4

B	22.06.04	C. Longuet	A. Lairault	D. Dunoyer	Mise à jour/Up to date
A	23.01.02	C. Longuet	A. Lairault	D. Dunoyer	Etablissement du plan
Indice Index	Date Date	Rédigé Issued by	Vérifié Checked by	Approuvé Approved by	Objet de la modification Modification object

Titre - Title	ROBINET A SOUPE "Serflo" GLOBE VALVE			Figure - Figure	Orifice - Orifice
	3193 07			15 à 50	

Toute reproduction est interdite, sans l'autorisation de SNRI -



