

50	Volant Handwheel	Alpax Alpax
22	Fouloir Gland	Acier inox Z10 CNF18-09 Stainless steel AISI 303
11	Tige Stem	Acier inox Z6 CND16.05.01 Stainless steel A564 Type 632
21	Garniture d'étanchéité Packing	PTFE PTFE
1	Corps Body	Acier inox Z 2 CND 17 12 Stainless steel AISI 316 L
REP MARK	DESIGNATION DESIGNATION	MATIERE (AFNOR) MATERIAL (ASTM/AISI)

REFERENCES - REFERENCES

Les nuances ASTM/AISI ne figurent qu'à titre indicatif - *ASTM/AISI materials are not contractual*
 Construction - *Construction* : -
 Raccordement - *Connection* : Manchons taraudés gaz suivant NFE 03.005 (12/81)
 Limites d'emploi - *Limit use* : 160 bars/110°C - 100 bars/180°C
 Essais - *Testing* : NFE 29.311 (06/82), taux d'étanchéité 2
 Courbe pression / TC - *Pressure / TC curve* : NFE 29.005 (91), ISO 7005-1 (04/92)

OPTIONS - OPTIONS

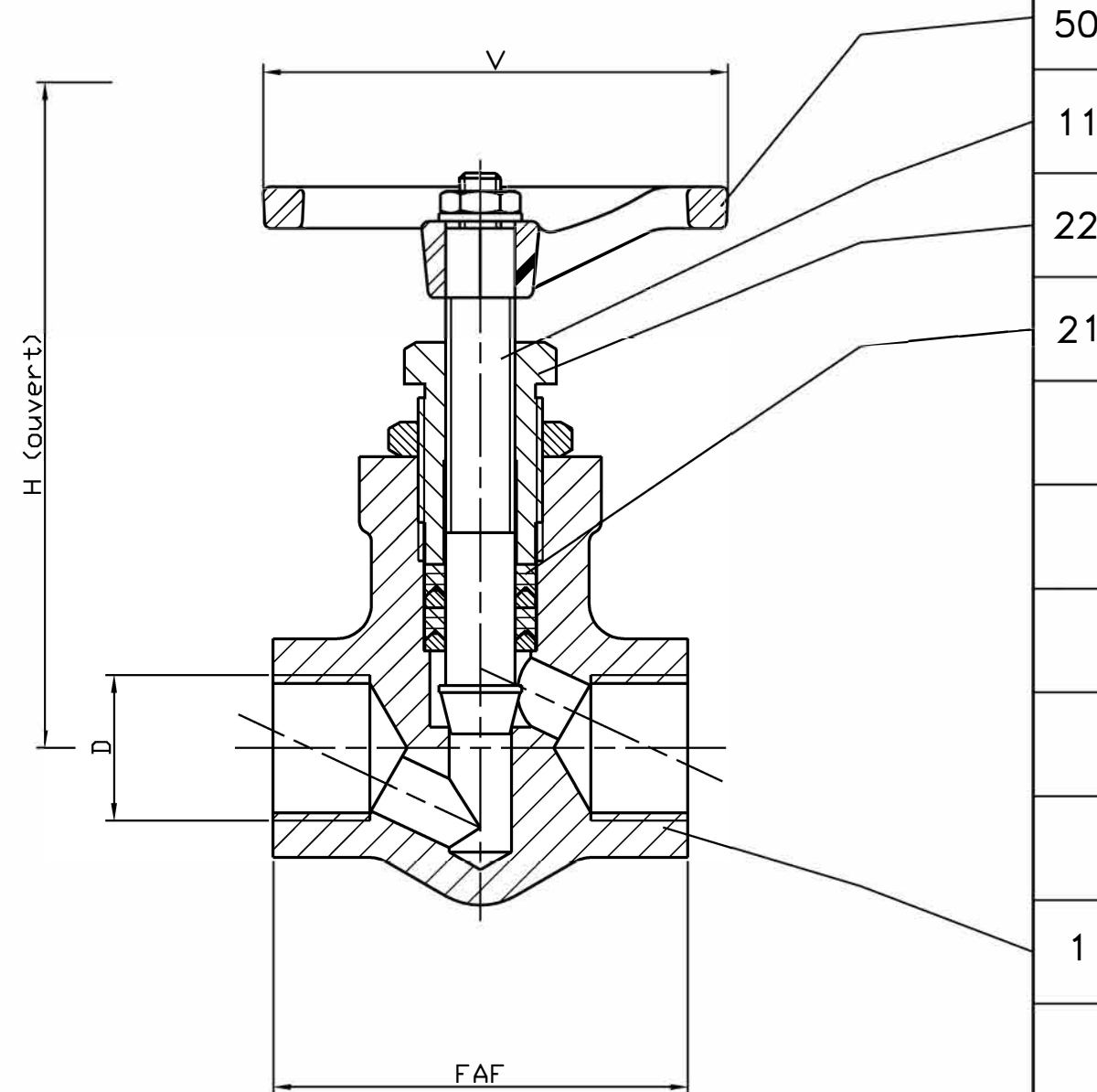

DN	8	10	15	20					
Catégorie suivant DESP - <i>Type in accordance with PED : 97/23/CE</i>	art. 3.3	art. 3.3	art. 3.3	art. 3.3					
FAF mm	50	50	60	80					
D mm	8x13	12x17	15x21	20x27					
V mm	50	50	63	80					
H (Ouvert) (Opened) mm	69	73	88	118					
Masse - <i>Weight</i> kg	0,240	0,360	0,570	1					

A	29.07.02	C. Longuet	A. Lairault	D. Dunoyer	Etablissement du plan
Indice Index	Date Date	Rédigé Issued by	Vérifié Checked by	Approuvé Approved by	Objet de la modification Modification object
Titre - <i>Title</i>	ROBINET A POINTEAU "Uniroc" NEEDLE VALVE			Figure - <i>Figure</i>	Orifice - <i>Orifice</i>
				3230 07	8 à 20
Toute reproduction est interdite, sans l'autorisation de SNRI					-
