

50	Volant <i>Handwheel</i>	Alpax <i>Alpax</i>
22	Fouloir <i>Gland</i>	Laiton Cu Zn40 <i>Brass</i>
11	Tige <i>Stem</i>	Acier inox Z20 C13 <i>Stainless steel AISI 420</i>
21	Garniture d'étanchéité <i>Packing</i>	PTFE <i>PTFE</i>
4	Siège / Portée d'étanchéité <i>Seat / Tightness-seating</i>	Acier inox Z10 CNF18-09 <i>Stainless steel AISI 303</i>
1	Corps <i>Body</i>	Laiton Cu Zn39Pb2 <i>Brass B124 Gr 377</i>
REP MARK	DESIGNATION <i>DESIGNATION</i>	MATIERE (AFNOR) <i>MATERIAL (ASTM/AISI)</i>

REFERENCES - REFERENCES

Les nuances ASTM/AISI ne figurent qu'à titre indicatif - *ASTM/AISI materials are not contractual*
 Construction - *Construction* : -
 Raccordement - *Connection* : Manchons taraudés gaz suivant NFE 03.005 (12/81)
 Limites d'emploi - *Limit use* : 100 bars/110°C - 20 bars/180°C
 Essais - *Testing* : NFE 29.311 (06/82), taux d'étanchéité 2
 Courbe pression / TC - *Pressure / TC curve* : NFE 29.005 (91), ISO 7005-1 (04/92)

OPTIONS - OPTIONS

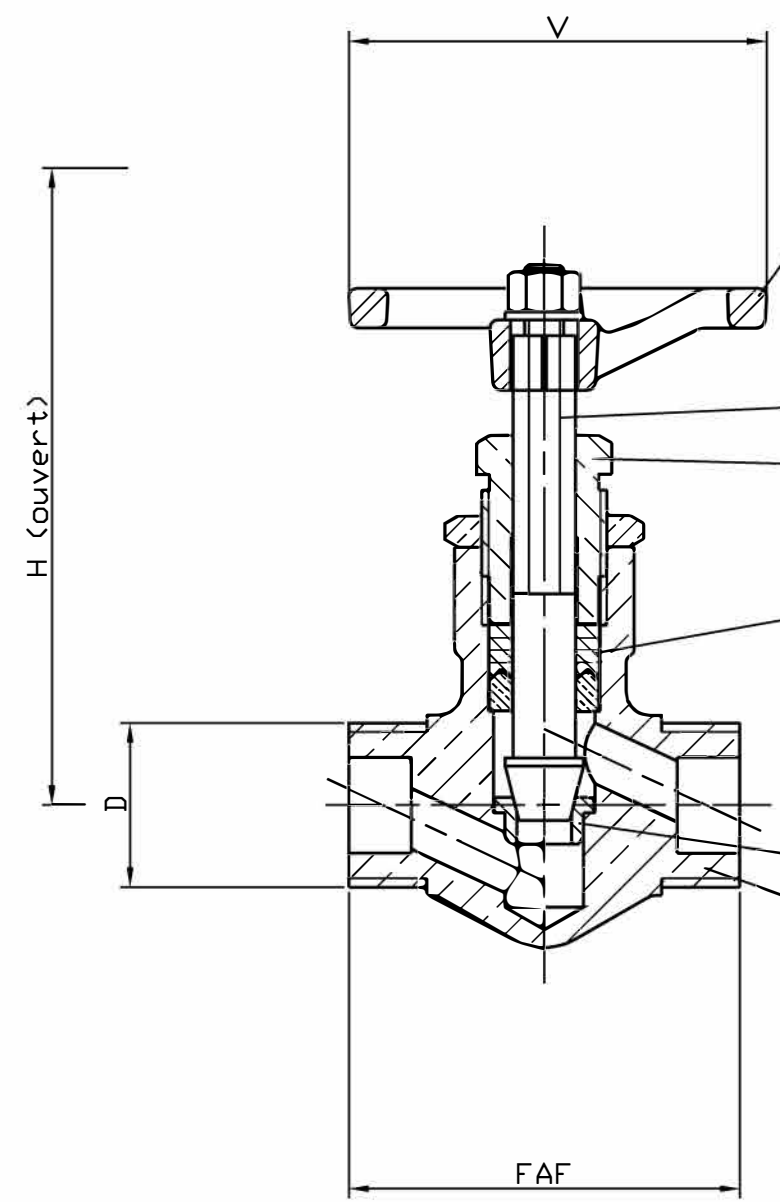

50
11
22
21
4
1

DN	8	10	15	20					
Catégorie suivant DESP - <i>Type in accordance with PED : 97/23/CE</i>	art. 3.3	art. 3.3	art. 3.3	art. 3.3					
FAF mm	50	50	50	60					
D mm	8x13	12x17	15x21	20x27					
V mm	50	50	50	63					
H (Ouvert) (Opened) mm	70	70	74	88					
Masse - <i>Weight</i> kg	0,2	0,2	0,3	0,520					

A	24.07.02	C. Longuet	A. Lairault	D. Dunoyer	Etablissement du plan	
Indice Index	Date	Rédigé Issued by	Vérifié Checked by	Approuvé Approved by	Objet de la modification Modification object	
Titre-Title	ROBINET A POINTEAU "Uniroc" NEEDLE VALVE				Figure - Figure 3221 03	Orifice - Orifice 8 à 20
	Toute reproduction est interdite, sans l'autorisation de SNRI					-

