

50	Poignée Handle	Fonte MN 380/18 Cast iron
21	Garniture Packing	Graphite Graphite
11	Tige Stem	Acier inox Z 20 C13 Stainless steel AISI 420
7	Joint corps/chapeau Body/bonnet gasket	Graphite Graphite
6	Boulonnerie corps/chapeau Body/bonnet bolting	Acier classe 10/9 Steel A 193 Gr B7 / A 194 Gr 2H
4	Siège / Portée d'étanchéité Seat / Tightness-seating	Acier A 480 CP-M / Stellite Steel A 216 Gr WCB / Stellite
3	Obturateur / Portée d'étanchéité Disc / Tightness-seating	Stellite Stellite
2	Chapeau Bonnet	Acier A 480 CP-M Steel A 216 Gr WCB
1	Corps Body	Acier A 480 CP-M Steel A 216 Gr WCB
REP MARK	DESIGNATION DESIGNATION	MATIERE (AFNOR) MATERIAL (ASTM/AISI)

REFERENCES - REFERENCES

Les nuances ASTM/AISI ne figurent qu'à titre indicatif - *ASTM/AISI materials are not contractual*  
 Construction - *Construction* : NFE 29.327 (02/85)  
 Raccordement - *Connection* : Brides, ISO PN40 , type 21, svt NFE 29.203 (07/89)  
 Classe de pression - *Pressure class* : ISO PN40  
 Essais - *Testing* : NFE 29.311 (06/82), taux d'étanchéité 2  
 Courbe pression / TC - *Pressure / TC curve* : NFE 29.005 (91), ISO 7005-1 (04/92)

OPTIONS - OPTIONS

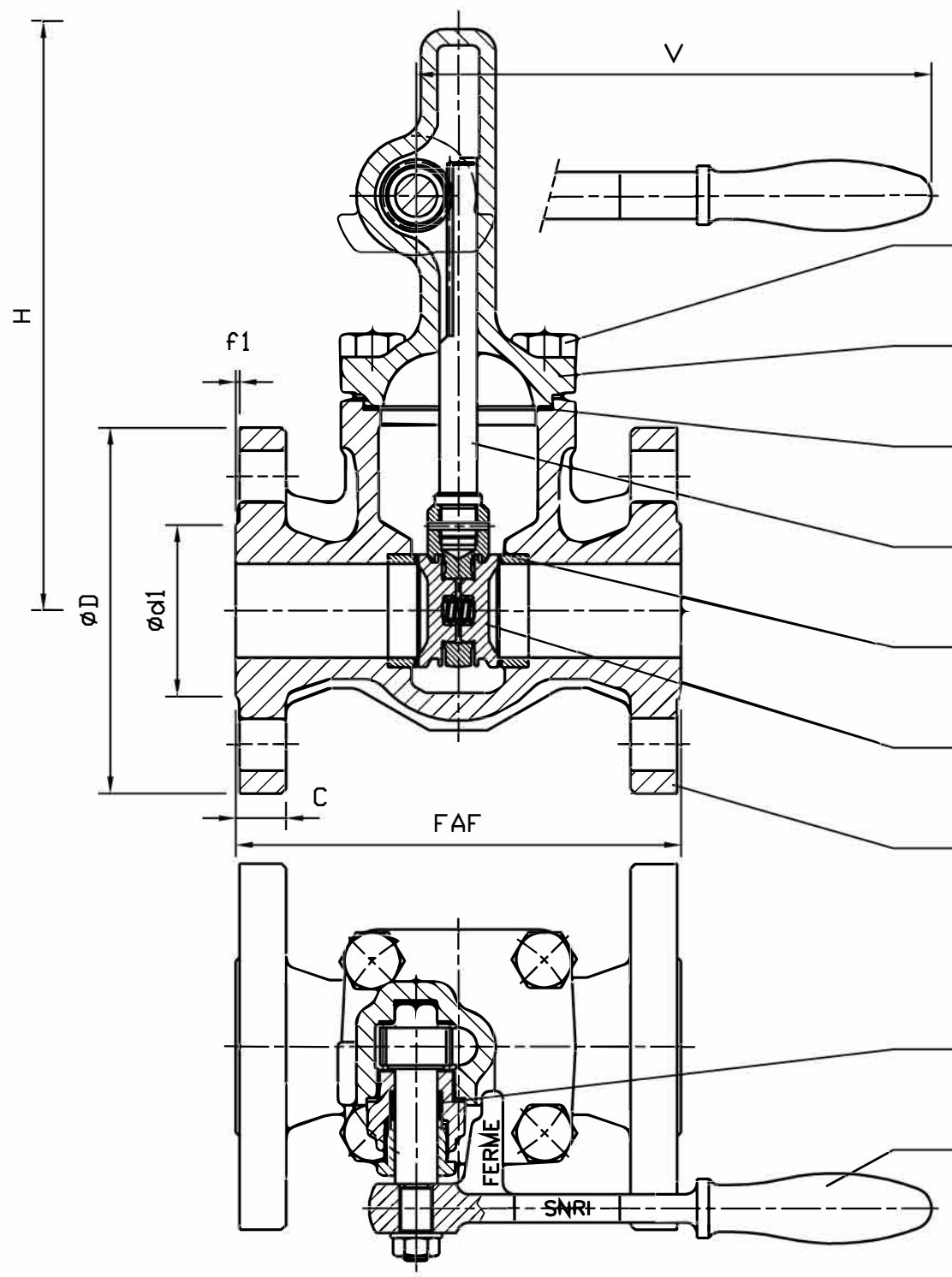

DN	20	32	40	50					
Catégorie suivant DESP - Type in accordance with PED : 97/23/CE	art 3.3	C2	C2	C2					
FAF mm	152	230	240	250					
øD/C mm	105/18	140/18	150/18	165/20					
Nbr/øTrou/øPerçage Nbr/øHole/øDrilling	4/14/75	4/18/100	4/18/110	4/18/125					
ød1/f1 mm	58/2	78/2	88/3	102/3					
V mm	157	215	238	272					
H maxi mm	245	327	365	447					
Kv	143	143	143	143					
Masse - Weight kg	4,8	8,6	11,4	20,5					

A	28.03.02	C. Longuet	A. Lairault	D. Dunoyer	Etablissement du plan	
Indice Index	Date Date	Rédigé Issued by	Vérifié Checked by	Approuvé Approved by	Objet de la modification Modification object	
Titre - Title	VANNE D'EXTRACTION "Stilfast" ISO PN 40 GATE VALVE				Figure - Figure	Orifice - Orifice
					2945   09	20 à 50
Toute reproduction est interdite, sans l'autorisation de SNRI					-	

