

| | | |
|-------------|--------------------------------------|---|
| 9 | Vis de réglage Adjusting screw | Z6 CND 17.12 A 564 type 632 |
| 8 | Ressort Spring | Acier XC 70 ou Inconel Steel A 229 Gr B or Inconel |
| 7 | Tige Stem | Acier inox Z 20 C13 Stainless steel AISI 420 |
| 6 | Joint Torique GASKET | FKM 70sh FKM 70sh |
| 5 | clapet surmoulé DISC | NBR 70 SCH NBR 70 SCH |
| 4 | Clapet / Portage Disc / Disc face | Acier inox Z 20 C13 Stainless steel AISI 420 |
| 3 | Chapeau Bonnet | A350 LF2 A350 LF2 |
| 2 | Buse Nozzle | Z7 CND 17.11.02 AISI 316 |
| 1 | Corps Body | Cu Sn5 Pb5 Zn5 B145 Gr4A |
| REP MARK | DESIGNATION DESIGNATION | MATIERE (AFNOR) MATERIAL (ASTM/AISI) |

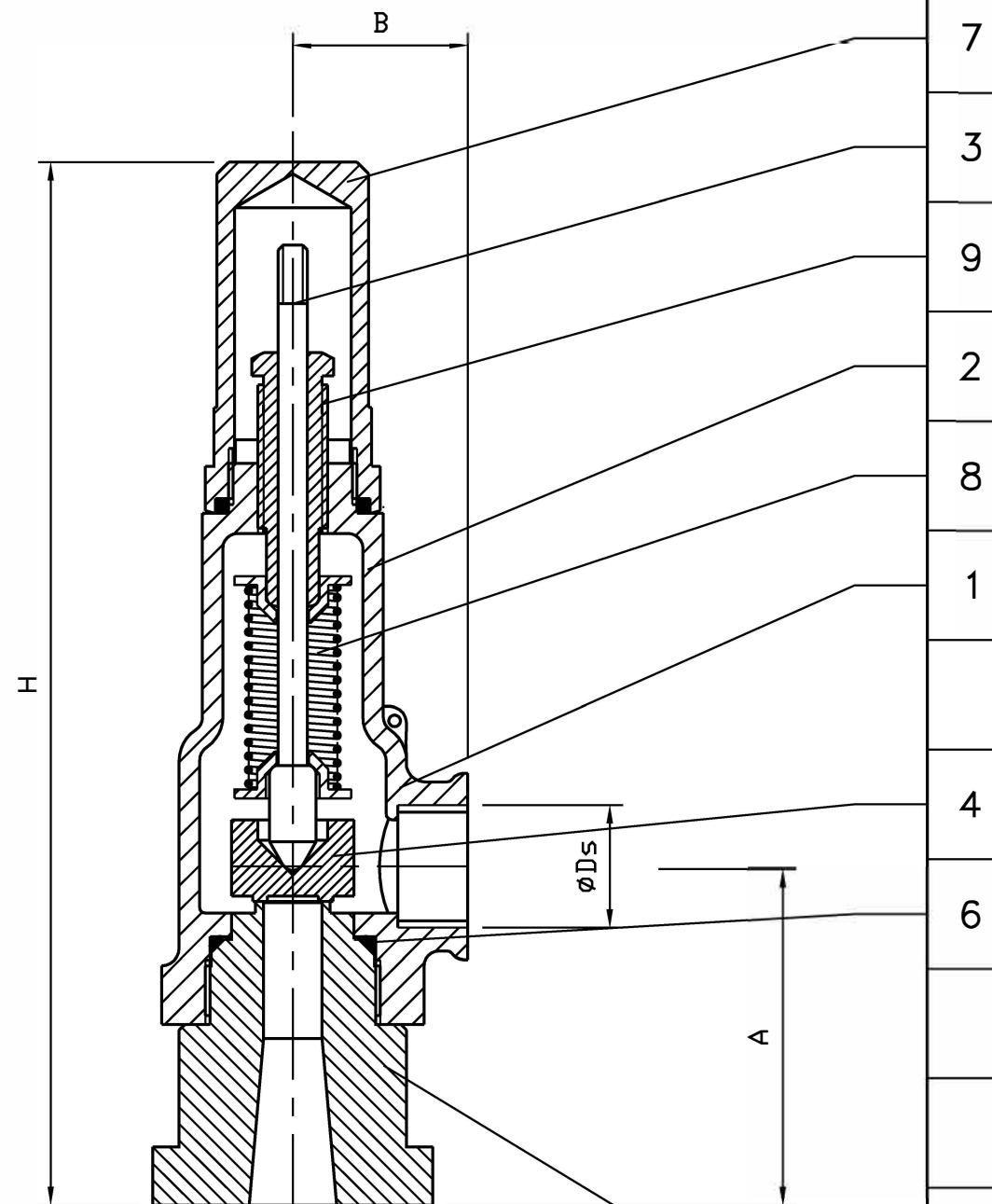
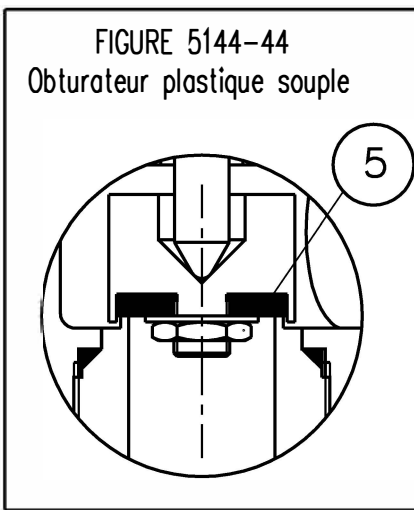

REFERENCES - REFERENCES

Les nuances ASTM/AISI ne figurent qu'à titre indicatif - *ASTM/AISI materials are not contractual*
 Construction - *Construction* : NFE 29.411 (12/88)
 Raccordement - *Connection* : Sortie taraudée gaz
 suivant norme NFE 03005 (décembre 1981)
 Conditions de service - *Service conditions* : 0.3 à 0.7 Bars,
 Essais - *Testing* : NFE 29.411 (12/88)

OPTIONS - OPTIONS

| | | | | | | | | | |
|--|----------------------------|-------|-------|-------|-------|-------|---------|-------|---------|
| DN | 15 | 20 | 25 | 32 | 40 | 50 | 65 | | |
| Catégorie suivant DESP - <i>Type in accordance with PED : 97/23/CE</i> | CAT.4 | CAT.4 | CAT.4 | CAT.4 | CAT.4 | CAT.4 | CAT.4 | | |
| A | mm | 58 | 67 | 72 | 82.5 | 90 | 100 | 115.5 | |
| B | mm | 30 | 35 | 40 | 50 | 58 | 65 | 70 | |
| H | mm | 178.5 | 199 | 210 | 251.5 | 274 | 315 | 340.5 | |
| ØDs | Filetage Gaz Thread Gas | mm | G 1/2 | G 3/4 | G 1 | G 1/4 | G 1 1/2 | G 2 | G 2 1/2 |
| Masse - <i>Weight</i> | kg | 0,9 | 1,3 | 1,7 | 2,5 | 3,2 | 4,8 | 10,4 | |

| | | | | | |
|---|---|---------------------|-----------------------|-------------------------------|---|
| B | 24/05/04 | O MAGNAN | A LAIRAULT | Standardisation gamme soupape | |
| A | 19/03/03 | O MAGNAN | A LAIRAULT | Etablissement du plan | |
| Indice Index | Date Date | Rédigé Issued by | Vérifié Checked by | Approuvé Approved by | Objet de la modification Modification object |
| Titre - <i>Title</i> | SOUPAPE DE SURETE "Bravid" SAFETY VALVE | | | Figure - <i>Figure</i> | Orifice - <i>Orifice</i> |
| | | | | 5144 33/34 | 15à65 |
| Toute reproduction est interdite, sans l'autorisation de SNRI | | | | | |
| | | | | | |