

50	Volant Handwheel	Alpax Alpax
21	Garniture d'étanchéité Packing	Graphite Graphite
11	Tige Stem	Acier inox Z10 CF17 Stainless steel AISI 430
4	Siège Seat	Acier inox Z10 CF17 Stainless steel AISI 430
3	Obturateur/Portage Disc/Disc face	Acier inox Z30 C13 Stainless steel AISI 420
2	Chapeau Bonnet	Acier XC18 Steel A105
1	Corps Body	Acier A48 CP Steel A515 Gr.70
REP MARK	DESIGNATION DESIGNATION	MATIERE (AFNOR) MATERIAL (ASTM/AISI)

REFERENCES - REFERENCES

Les nuances ASTM/AISI ne figurent qu'à titre indicatif - *ASTM/AISI materials are not contractual*  
 Construction - *Construction* : -  
 Raccordement - *Connection* : Manchons taraudés gaz suivant NFE 03.005 (12/81)  
 Limites d'emploi - *Limit use* : 320 bars/110°C - 100 bars/250°C  
 Essais - *Testing* : NFE 29.311 (06/82), taux d'étanchéité 2  
 Courbe pression / TC - *Pressure / TC curve* : NFE 29.005 (91), ISO 7005-1 (04/92)

OPTIONS - OPTIONS

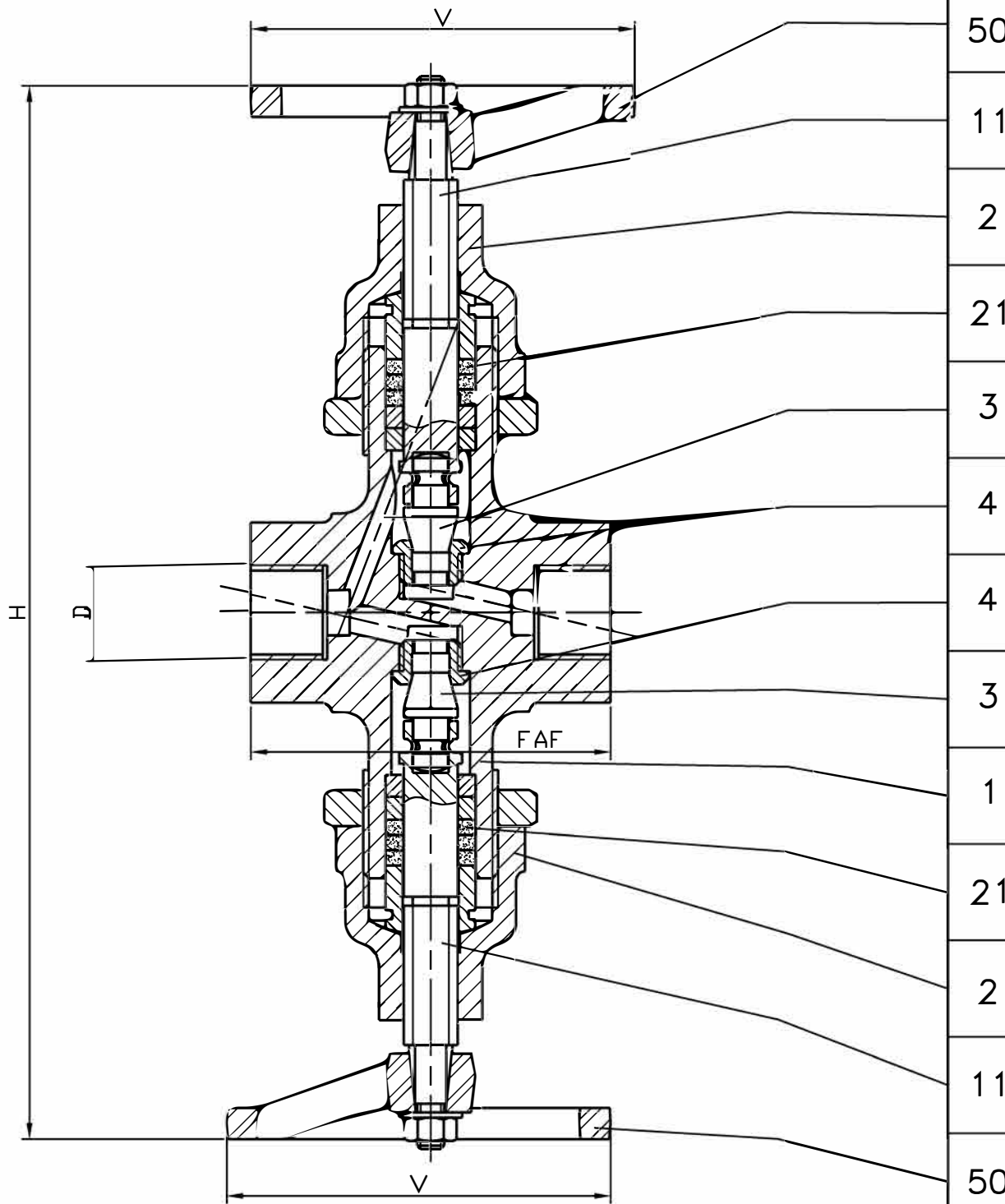

DN	15								
Catégorie suivant DESP - <i>Type in accordance with PED : 97/23/CE</i>	art. 3.3								
FAF mm	80								
D mm	15x21								
V mm	80								
H mm	255								
Masse - <i>Weight</i> kg	2,3								

A	20.01.03	C. Longuet	A. Lairault	D. Dunoyer	Etablissement du plan				
Indice Index	Date Date	Rédigé Issued by	Vérfié Checked by	Approuvé Approved by	Objet de la modification Modification object				
Titre - <i>Title</i>	ROBINET D'ARRET ET DE CONTROLE "Manoroc" SHUT OFF COCK / VALVE				Figure - <i>Figure</i>	6437   17		Orifice - <i>Orifice</i>	
					Toute reproduction est interdite, sans l'autorisation de SNRI		-		

