

6	Tamis Screen	Acier inox Z2 CN1810 Stainless steel AISI 304L
5	Siège/Portage Seat/Seating face	Acier inox Z20 C13 Stainless steel AISI 420
4	Boulonnerie corps/chapeau Body/bonnet bolting	Acier classe 10/9 Steel A193 Gr.B7/A194 Gr.2H
3	Joint corps/chapeau Body/bonnet gasket	Graphite Graphite
2	Chapeau Bonnet	Fonte FGS 400-15 Cast Iron A 536 Gr 60.40.18
1	Corps Body	Fonte FGS 400-15 Cast Iron A 536 Gr 60.40.18

REP MARK	DESIGNATION DESIGNATION	MATIERE (AFNOR) MATERIAL (ASTM/AISI)
----------	-------------------------	--------------------------------------

REFERENCES - REFERENCES

Les nuances ASTM/AISI ne figurent qu'à titre indicatif - ASTM/AISI materials are not contractual

Construction - Construction : -

Raccordement - Connection : Manchons taraudés gaz suivant NFE 03.005 (12/81)

Limites d'emploi - Limit use : NFE 29.006 (07/83)

Essais - Testing : NFE 29.311 (06/82)

Courbe pression / TC - Pressure / TC curve : NFE 29.006 (07/83)

OPTIONS - OPTIONS

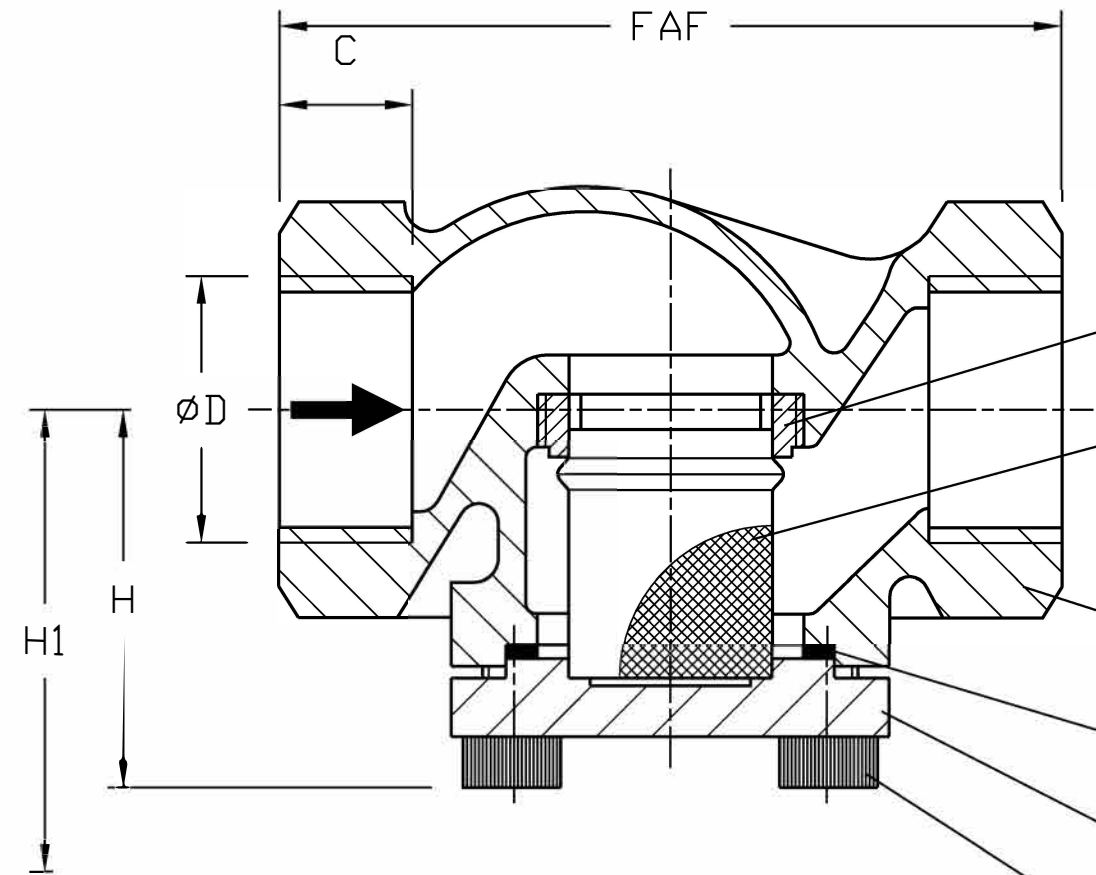

DN	15	20	25					
Catégorie suivant DESP - Type in accordance with PED : 97/23/CE	art. 3.3	art. 3.3	art. 3.3					
FAF mm	70	85	100					
D mm	15x21	20x27	26x34					
C mm	13	15	17					
H mm	46	55	58					
H1 (démontage) mm	60	72	80					
Masse - Weight kg	0,5	0,9	1,1					

A	31.07.03	C. Longuet	A. Lairault	-	Etablissement du plan/First issue
Indice Index	Date Date	Rédigé Issued by	Vérifié Checked by	Approuvé Approved by	Objet de la modification Modification object
Titre - Title	FILTRE A TAMIS "Purfix" ISO PN25 SCREEN FILTER			Figure - Figure	Orifice - Orifice
				4884   07	15 à 25

Toute reproduction est interdite, sans l'autorisation de SNRI