

6	Filtre Screen	Acier inox Z 2 CN18.10 Stainless steel AISI 304L
5	Siège / Portée d'étanchéité Seat / Tightness-seating	Acier inox Z20 C13 Stainless steel AISI 420
4	Boulonnerie Bolting	Acier classe 10/9 Steel A193 Gr.B7/ A 194 Gr.2H
3	Joint Gasket	Graphite Graphite
2	Couvercle Cover	Bronze Cu Sn5 Pb5 Zn5 Bronze B145 Gr 4A
1	Corps Body	Bronze Cu Sn5 Pb5 Zn5 Bronze B145 Gr 4A
REP MARK	DESIGNATION DESIGNATION	MATIERE (AFNOR) MATERIAL (ASTM/AISI)

**REFERENCES - REFERENCES**

Les nuances ASTM/AISI ne figurent qu'à titre indicatif - *ASTM/AISI materials are not contractual*  
 Construction - *Construction* : -  
 Raccordement - *Connection* : Taraudage pas du gaz, NFE 03.005 (12/81)  
 Conditions de service - *Service conditions* : 30 bar/110°C - 20 bar/180°C  
 Essais - *Testing* : NFE 29.311 (06/82)  
 Plage admissible T°C - *Admissible range T°C* : -10°C +260°C

OPTIONS - OPTIONS

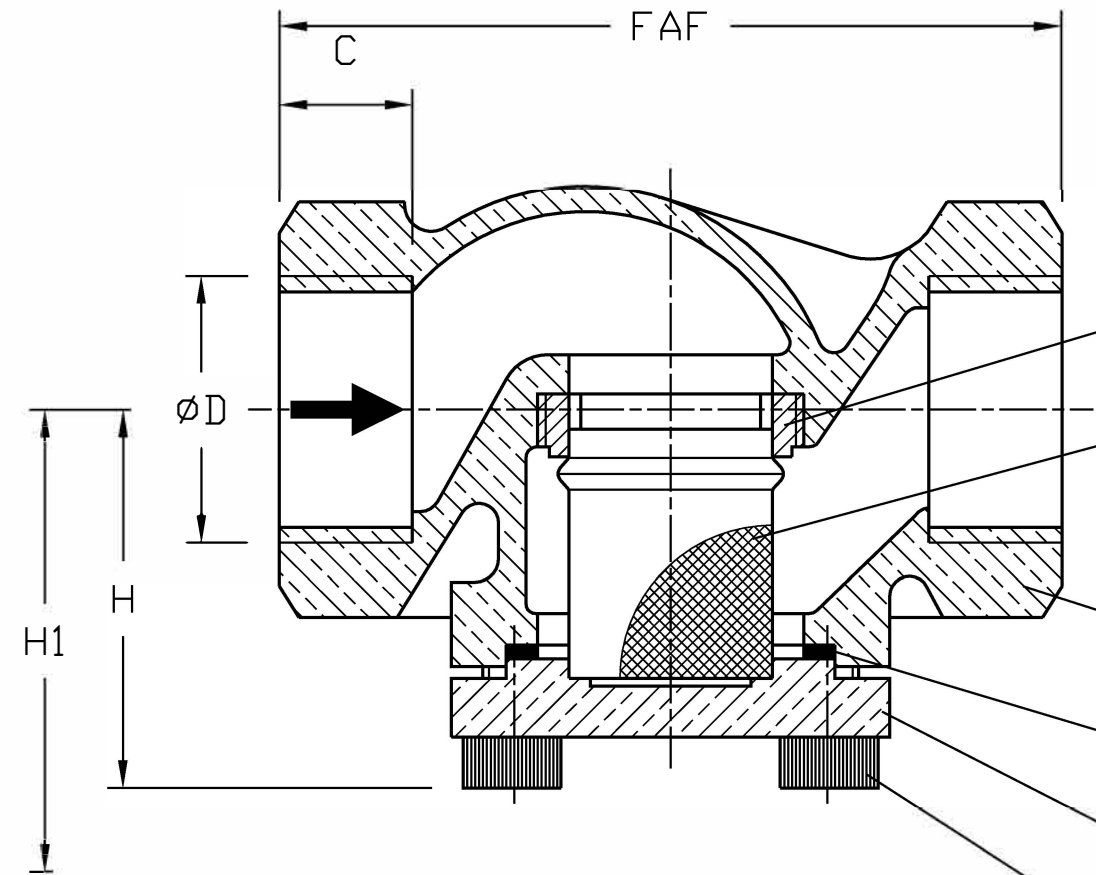

DN	15	20	25	32	40	50		
Catégorie suivant DESP - <i>Type in accordance with PED : 97/23/CE</i>	art. 3.3	art. 3.3	art. 3.3	art. 3.3	C1	C1		
FAF mm	70	85	100	120	135	170		
ØD mm	15x21	20x27	26x34	33x42	40x49	50x60		
C mm	13	15	17	19	20	22		
H mm	46	55	58	80	100	100		
H1 (Démontage) (Dismantling) mm	60	72	80	112	131	141		
Masse - <i>Weight</i> kg	0,5	1	1,2	2,3	2,8	4,3		

A	30.07.03	C. Longuet	A. Lairault	-	Etablissement du plan/First issue
Indice Index	Date Date	Rédigé Issued by	Vérifié Checked by	Approuvé Approved by	Objet de la modification Modification object
Titre - <i>Title</i>	FILTRE A TAMIS "Purfix" STRAINER			Figure - <i>Figure</i>	Orifice - <i>Orifice</i>
				4854   07	15 à 50
Toute reproduction est interdite, sans l'autorisation de SNRI					