

83	Tuyère motrice <i>Motive pipe</i>	Laiton Cu Zn40 <i>Brass</i>
82	Tuyère mélange <i>Mixture pipe</i>	Laiton Cu Zn40 <i>Brass</i>
1	Corps <i>Body</i>	Bronze Cu Sn5 Pb5 Zn5 <i>Bronze B145 Gr 4A</i>
REP MARK	DESIGNATION <i>DESIGNATION</i>	MATIERE (AFNOR) <i>MATERIAL (ASTM/AISI)</i>

REFERENCES - REFERENCES

Les nuances ASTM/AISI ne figurent qu'à titre indicatif - *ASTM/AISI materials are not contractual*
Raccordement - *Connection* : Manchons taraudés et filetés gaz svt NFE 03.005 (12/81)
Pression d'eau (fluide moteur) - *Water pressure* : de 1,5 à 10 bars

Courbe pression / TC - *Pressure / TC curve* : -10°C +260°C

OPTIONS - OPTIONS

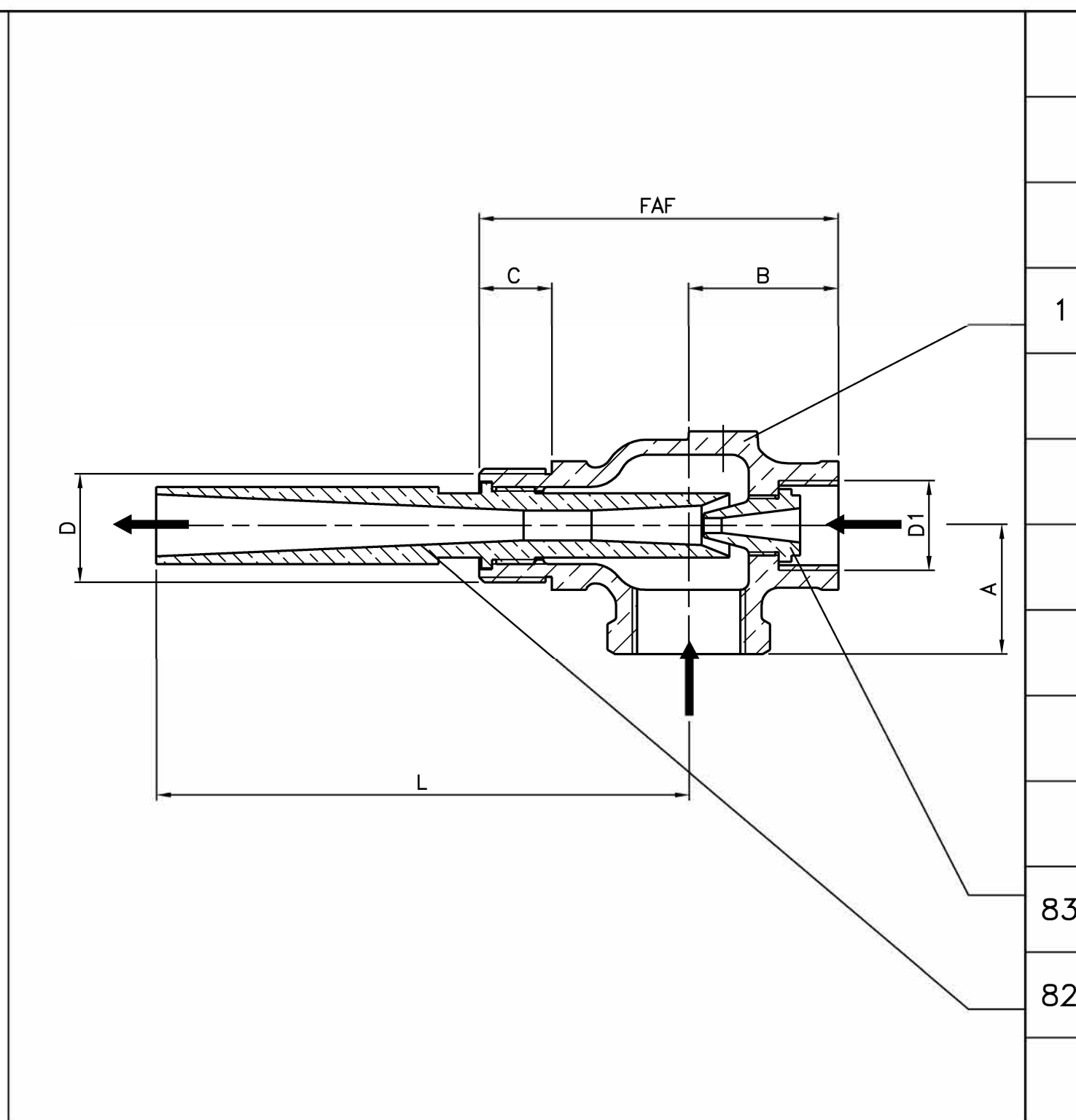

DN	15	20	25	32	40	50			
Catégorie suivant DESP - <i>Type in accordance with PED : 97/23/CE</i>	art. 3.3	art. 3.3	art. 3.3	art. 3.3	art. 3.3	art. 3.3			
FAF	mm	74	84	97	111	121	143		
A/B	mm	25/31	30/35	35/41	40/49	45/51	50/63		
L	mm	89	125	153	186	239	292		
D	mm	15x21	20x27	26x34	33x42	40x49	50x60		
D1	mm	12x17	15x21	20x27	26x34	26x34	33x42		
C	mm	15	17	19	22	22	25		
Masse - <i>Weight</i>	kg	0,4	0,6	1	1,7	2,2	4		

Indice <i>Index</i>	Date <i>Date</i>	Rédigé <i>Issued by</i>	Vérfié <i>Checked by</i>	Approuvé <i>Approved by</i>	Objet de la modification <i>Modification object</i>
B	06.11.03	C. Longuet	L. Couvertier	D. Dunoyer	Mise à jour/ <i>Up to date</i>
A	22.01.03	C. Longuet	A. Lairault	D. Dunoyer	Etablissement du plan
EJECTEUR A JET D'EAU "FLUXERO" EJECTOR ELEVATOR					Figure - <i>Figure</i> 6219 01 Orifice - <i>Orifice</i> 15 à 50
Toute reproduction est interdite, sans l'autorisation de SNRI					

