

83	Tuyère motrice <i>Motive pipe</i>	Acier inox Z7 CND17.11.02 <i>Stainless steel AISI 316</i>
82	Tuyère mélange <i>Mixture pipe</i>	Acier inox Z2 CND17.12 <i>Stainless steel AISI 316L</i>
1	Corps <i>Body</i>	Acier inox Z6 CND18.12M <i>Stainless steel A 351 Gr CF8M</i>
REP MARK	DESIGNATION DESIGNATION	MATIERE (AFNOR) MATERIAL (ASTM/AISI)

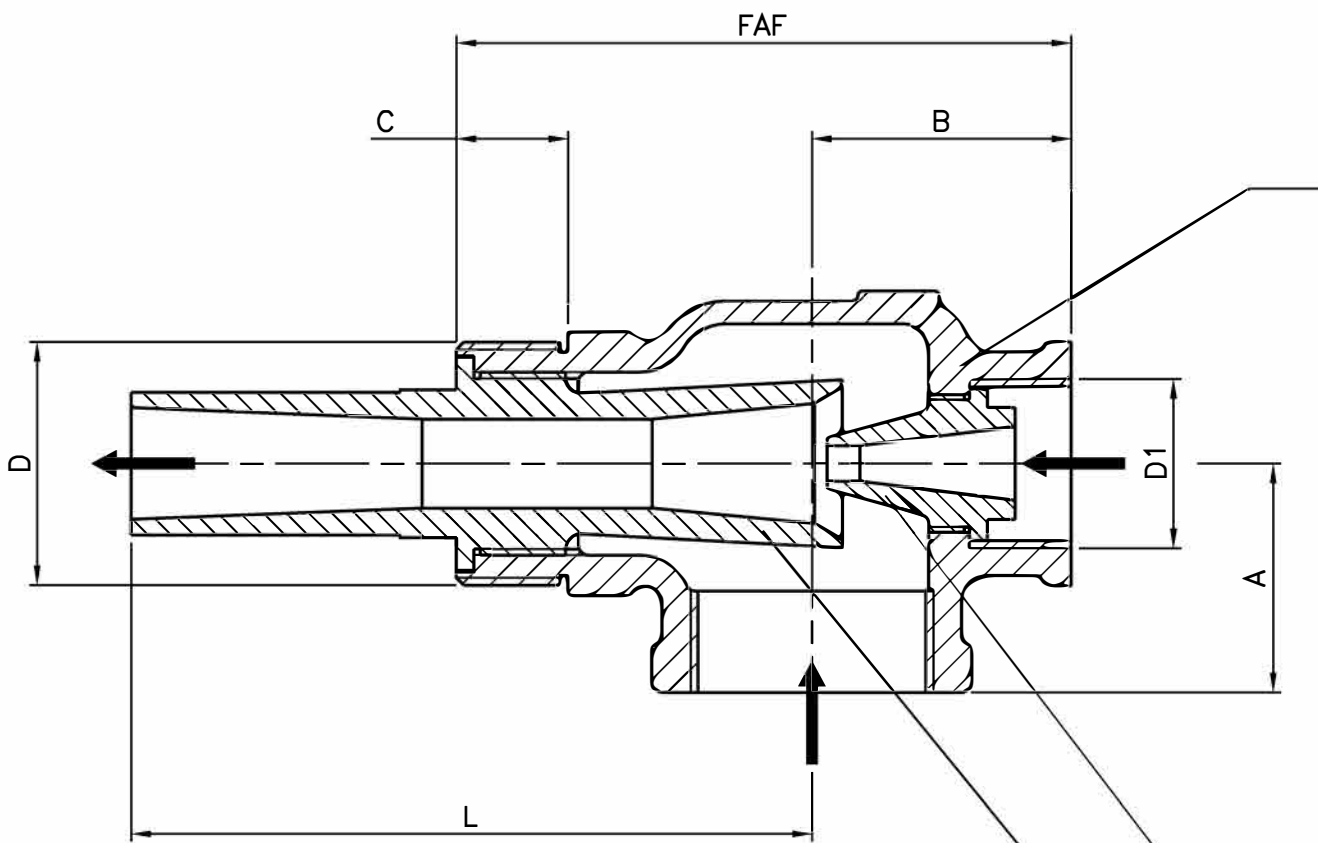

REFERENCES - REFERENCES

Les nuances ASTM/AISI ne figurent qu'à titre indicatif - *ASTM/AISI materials are not contractual*
 Raccordement - *Connection* : Manchons taraudés et filetés gaz svt NFE 03.005 (12/81)
 Pression d'eau (fluide moteur) - *Water pressure* : de 1,5 à 8 bars

OPTIONS - OPTIONS



DN	15	20	25	32	40	50
Catégorie suivant DESP - <i>Type in accordance with PED : 97/23/CE</i>	art. 3.3	art. 3.3	art. 3.3	art. 3.3	art. 3.3	art. 3.3
FAF mm	74	84	97	111	121	143
A/B mm	25/31	30/35	35/41	40/49	45/51	50/63
L mm	49	65	84	101	134	167
D mm	15x21	20x27	26x34	33x42	40x49	50x60
D1 mm	12x17	15x21	20x27	26x34	26x34	33x42
C mm	15	17	19	22	22	25
Masse - <i>Weight</i> kg	0,3	0,5	0,8	1,3	1,8	3,2

A	24.12.03	C. Longuet	L. Couvertier	-	Etablissement du plan/First issue
Indice Index	Date Date	Rédigé Issued by	Vérfié Checked by	Approuvé Approved by	Objet de la modification Modification object
Titre-Title	EJECTEUR A JET D'EAU "FLUXO" EJECTOR ELEVATOR			Figure - Figure	Orifice - Orifice
	Toute reproduction est interdite, sans l'autorisation de SNRI			6206 67	15 à 50
	 				

1

83

82