

83	Tuyère motrice <i>Motive pipe</i>	Laiton Cu Zn40 <i>Brass</i>
82	Tuyère mélange <i>Mixture pipe</i>	Laiton Cu Zn40 <i>Brass</i>
1	Corps <i>Body</i>	Bronze Cu Sn5 Pb5 Zn5 <i>Bronze B145 Gr 4A</i>
REP MARK	DESIGNATION DESIGNATION	MATIERE (AFNOR) MATERIAL (ASTM/AISI)

REFERENCES - REFERENCES

Les nuances ASTM/AISI ne figurent qu'à titre indicatif - *ASTM/AISI materials are not contractual*
 Raccordement - *Connection* : Brides, ISO PN16, type 13, NFE 29.203 (07/89)
 Pression de vapeur (fluide moteur) - *Vapour pressure* : de 2 à 10 bars

OPTIONS - OPTIONS

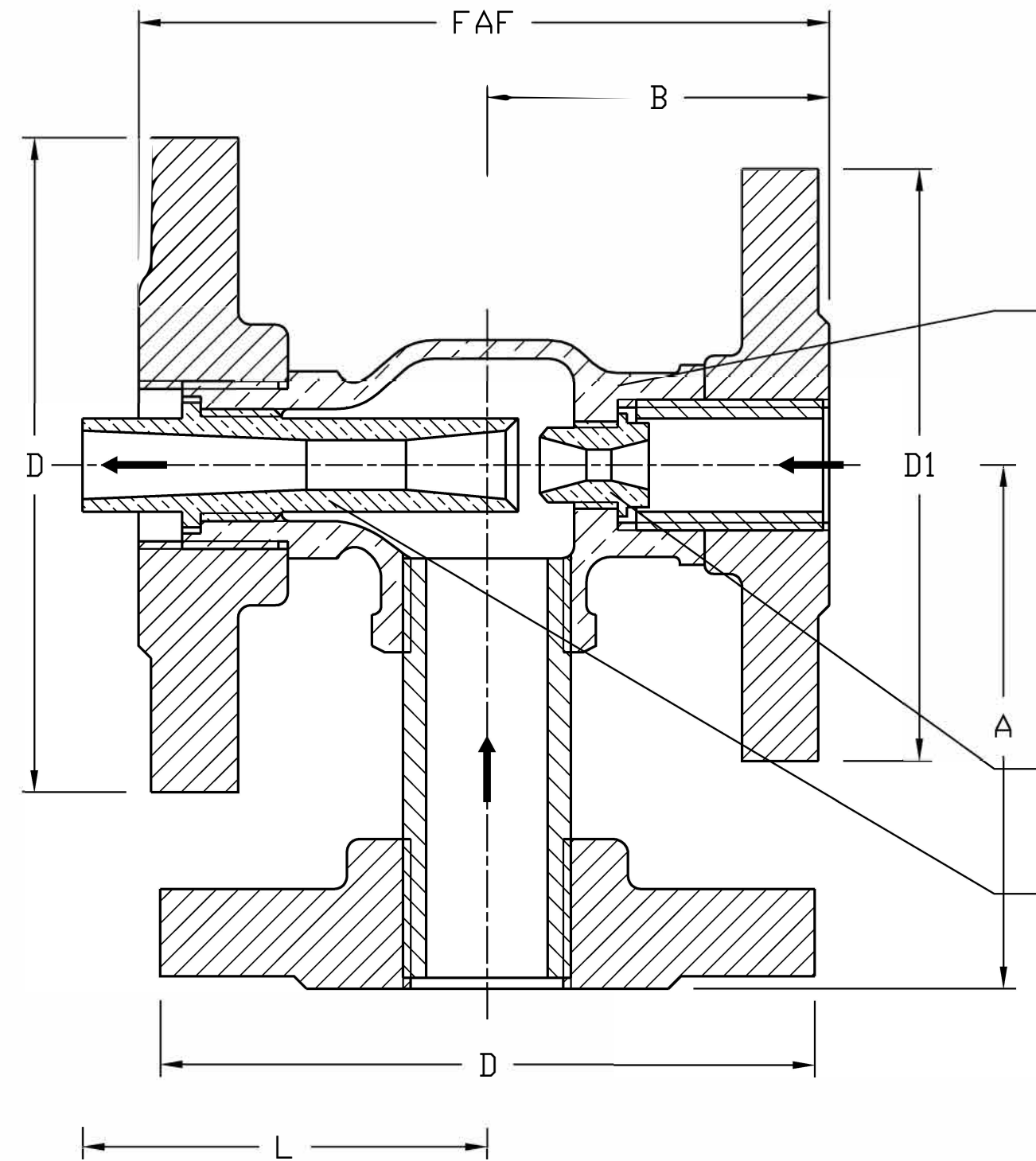

1
82
83

DN	15	20	25	32	40	50
Catégorie suivant DESP - <i>Type in accordance with PED : 97/23/CE</i>	art. 3.3	art. 3.3	art. 3.3	art. 3.3	art. 3.3	art. 3.3
FAF mm	99	111	127	139	151	172
A/B mm	77/51	84/55	88/65	102/73	107/77	115/89
L mm	49	65	84	101	134	167
D mm	95	105	115	140	150	165
D1 mm	90	95	105	115	115	140
Masse - <i>Weight</i> kg	2,5	3,3	4,2	6,1	7,5	10,7

A	24.06.04	C. Longuet	A. Lairault	D. Dunoyer	Etablissement du plan/First issue
Indice Index	Date Date	Rédigé Issued by	Vérifié Checked by	Approuvé Approved by	Objet de la modification Modification object
Titre - <i>Title</i>	EJECTEUR A JET D'EAU "FLUXERO" EJECTOR ELEVATOR		RECHAUFFEUR "THERMOFLUX" HEATER		Figure - <i>Figure</i>
	6202		01		Orifice - <i>Orifice</i> 15 à 50
Toute reproduction est interdite, sans l'autorisation de SNRI					-

