

50	Volant <i>Handwheel</i>	Alpax AS13 Y30 <i>Alpax</i>
11	Tige <i>Stem</i>	Acier inox Z10 CF17 <i>Stainless steel AISI 430</i>
9	Ressort <i>Spring</i>	Acier XC70 <i>Steel/AISI 1070</i>
7	Joint <i>Gasket</i>	NBR 70SH <i>BNR 70SH</i>
6	Boulonnerie <i>Gland bolting</i>	Acier 42 CD4/classe 10 <i>Steel A193 Gr. B7/A194 Gr.2H</i>
4	Siège / Portée d'étanchéité <i>Seat / Tightness-seating</i>	Acier inox Z15 CN16.02 <i>Stainless steel AISI 431</i>
3	Obturateur / Portée d'étanchéité <i>Disc / Tightness-seating</i>	UA9 NFE <i>B148 Gr.9B</i>
2	Cylindre <i>Cylinder</i>	Laiton Cu Zn40 <i>Brass</i>
1	Corps <i>Body</i>	Acier A 480 CP-M <i>Steel A 216 Gr WCB</i>
REP MARK	DESIGNATION DESIGNATION	MATIERE (AFNOR) MATERIAL (ASTM/AISI)

REFERENCES REFERENCES

Les nuances ASTM/AISI ne figurent qu'à titre indicatif - *ASTM/AISI materials are not contractual*
 Construction - *Construction* : -
 Raccordement - *Connection* : Filetage gaz, NFE 03.005
 Pression amont - *Upstream pressure* : jusqu'à 250 bars/80°C
 Pression aval admissible - *Downstream pressure* : 3 à 20 bars
 Plage admissible T°C - *Admissible range T°C* : NFE 29.005 (91), ISO 7005-1 (04/92)

OPTIONS - OPTIONS

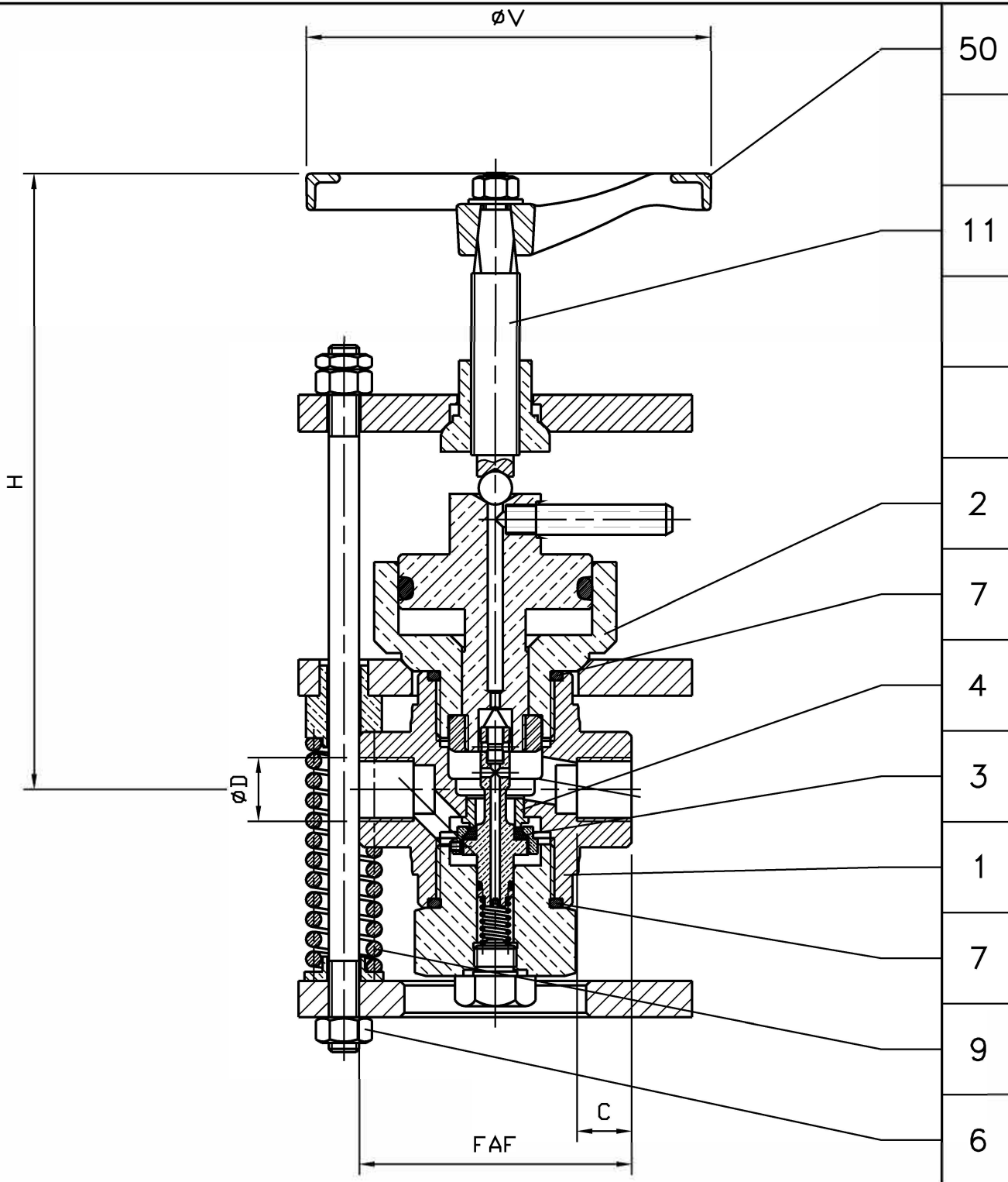

DN	15								
Catégorie suivant DESP - <i>Type in accordance with PED : 97/23/CE</i>	art. 3.3								
FAF	mm	90							
øD	mm	15x21							
C	mm	18							
øV	mm	125							
H	mm	188							
Masse - <i>Weight</i>	kg	7							

A	30.09.03	C. Longuet	A.Lairault	D.Dunoyer	Etablissement du plan/First issue
Indice Index	Date Date	Rédigé Issued by	Vérifié Checked by	Approuvé Approved by	Objet de la modification Modification object
Titre - <i>Title</i>	REDUCTEUR - REGULATEUR "Blackwell" PRESSURE REGULATOR			Figure - <i>Figure</i>	Orifice - <i>Orifice</i>
				6069 02	15
Toute reproduction est interdite, sans l'autorisation de SNRI					-

