

42	Plateau de membrane <i>Diaphragm plate</i>	Laiton Cu Zn40 <i>Brass</i>
22	Boulonnerie <i>Gland bolting</i>	Acier classe 10/9 <i>Steel A193 Gr.B7/ A 194 Gr.2H</i>
16	Joint torique <i>O ring</i>	NBR <i>NBR</i>
14	Ressort <i>Spring</i>	Acier XC70 <i>Steel/AISI 1070</i>
10	Joint <i>Gasket</i>	Graphite <i>Graphite</i>
9	Ressort <i>Spring</i>	Acier inox Z 10 CN18.09 <i>Stainless steel AISI 302</i>
8	Guide <i>Guide</i>	Laiton Cu Zn40 <i>Brass</i>
4	Porte clapet / Clapet <i>Disc holder / Disc</i>	Cu Zn40 / Ethylène propylène <i>Brass / Ethylene propylene</i>
3	Membrane <i>Diaphragm</i>	Novagom <i>Novagom</i>
2	Chapeau <i>Bonnet</i>	Bronze Cu Zn5 Pb5 Zn5 <i>Bronze B145 Gr 4A</i>
1	Corps <i>Body</i>	Bronze Cu Zn5 Pb5 Zn5 <i>Bronze B145 Gr 4A</i>
REP MARK	DESIGNATION DESIGNATION	MATIERE (AFNOR) MATERIAL (ASTM/AISI)

REFERENCES - REFERENCES

Les nuances ASTM/AISI ne figurent qu'à titre indicatif - *ASTM/AISI materials are not contractual*
 Construction - *Construction* : -
 Raccordement - *Connection* : Filetage gaz, NFE 03.005
 Pression amont - *Upstream pressure* : jusqu'à 15 bars/80°C
 Pression aval admissible - *Downstream pressure* : 1 à 3 bars
 Plage admissible T°C - *Admissible range T°C* : -10°C +260°C

OPTIONS - OPTIONS

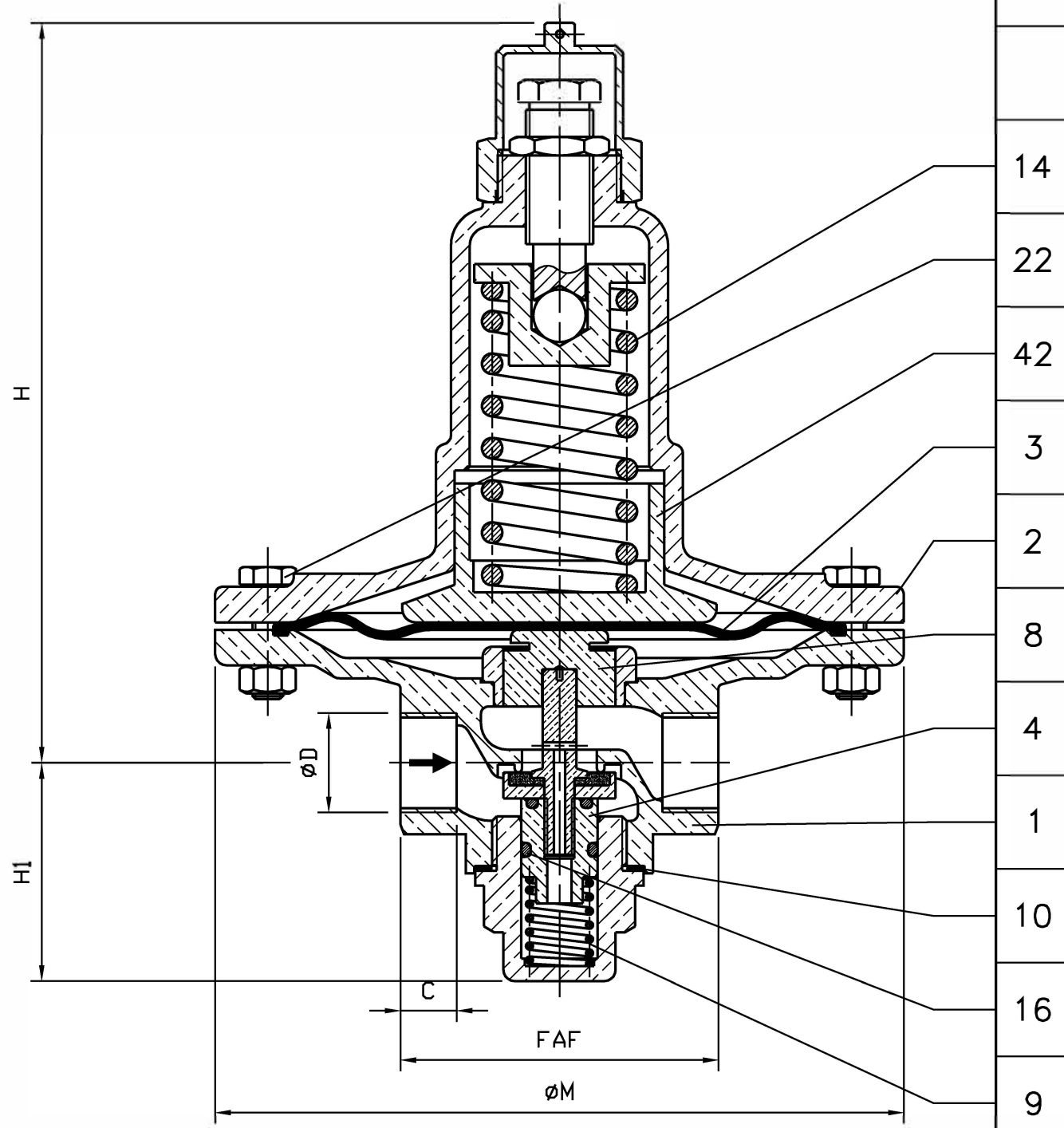

DN	10	15	20	25				
Catégorie suivant DESP - <i>Type in accordance with PED : 97/23/CE</i>	art. 3.3	art. 3.3	art. 3.3	art. 3.3				
FAF mm	54	70	85	100				
øD mm	12x17	15x21	20x27	26x34				
C mm	11	11	15	17				
øM mm	80	110	130	150				
H mm	116	160	186	218				
H1 mm	37	48	53	66				
Masse - <i>Weight</i> kg	1,1	2,8	4,7	7				

A	04.09.03	C. Longuet	A. Lairault	D. Dunoyer	Etablissement du plan/First issue
Indice Index	Date Date	Rédigé Issued by	Vérifié Checked by	Approuvé Approved by	Objet de la modification Modification object

Titre - *Titre*
DETENDEUR "Sergowatt" PRESSURE REGULATOR
 Figure - *Figure* 6031 | 42 | Orifice - *Orifice* 10 à 25

Toute reproduction est interdite, sans l'autorisation de SNRI -



Robival
 ROBINETTERIE INDUSTRIELLE ET INSTRUMENTATION