

80	Glace Glass	Pyrex Pyrex
79	Volet Shutter	Acier inox Z8 CNDT17.12 Stainless steel AISI 316Ti
5	Boulonnerie Bolting	Acier inox Z6CN18.09 / Classe A4 Stainless steel AISI 304H/Stainless steel
4	Joint Gasket	Graphite Graphite
2	Bride Flange	Acier inox Z2 CND18.12-M Stainless steel A351 Gr CF3M
1	Corps Body	Acier inox Z2 CND18.12-M Stainless steel A351 Gr CF3M
REP MARK	DESIGNATION DESIGNATION	MATIERE (AFNOR) MATERIAL (ASTM/AISI)

REFERENCES - REFERENCES

Les nuances ASTM/AISI ne figurent qu'à titre indicatif - *ASTM/AISI materials are not contractual*
 Conditions de service maximum - *Maximum service conditions* : DN15 à 32 , 10 Bars/110°C
 DN40 à 50 , 8 Bars/110°C
 Raccordement - *Connection* : Brides, ISO PN10, type 21-B, NFE 29.203 (07/89)
 Classe de pression - *Pressure class* : ISO PN10
 Courbe pression / T°C - *Pressure / TC curve* : NFE 29.005 (91), ISO 7005-1 (04/92)

OPTIONS - OPTIONS

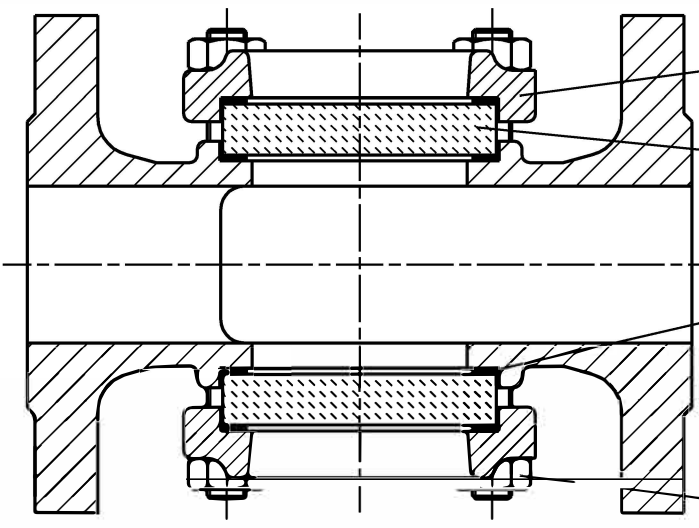
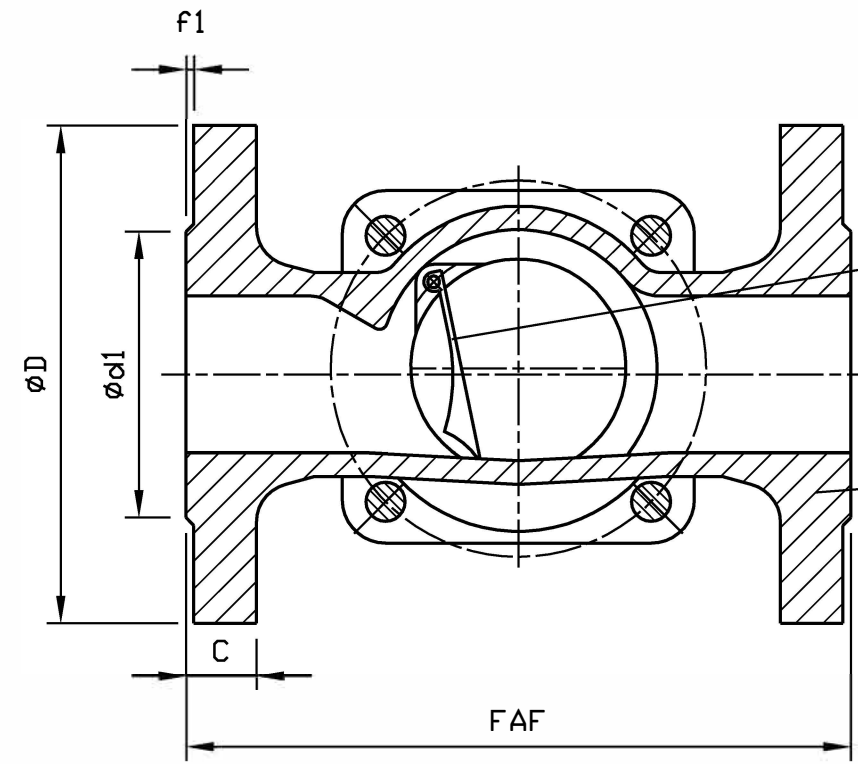

- 79
- 1
- 2
- 80
- 4
- 5

DN	15	20	25	32	40	50
Catégorie suivant DESP - <i>Type in accordance with PED : 97/23/CE</i>	art. 3.3	art. 3.3	art. 3.3	C1	C1	C1
FAF mm	135	135	140	150	170	170
øD / C mm	95/16	105/18	115/18	140/18	150/18	165/18
Nbr/øTrou/øPercage Nbr/øHole/øDrilling mm	4/14/65	4/14/75	4/14/85	4/18/100	4/18/110	4/18/125
ød1 / f1 mm	45/2	58/2	68/2	78/2	88/3	102/3
Masse - <i>Weight</i> kg	3	3,4	4	5,5	7,1	9,6

A	02.10.02	C. Longuet	A. Lairault	D. Dunoyer	Etablissement du plan/First issue
Indice Index	Date Date	Rédigé Issued by	Vérifié Checked by	Approuvé Approved by	Objet de la modification Modification object
Titre - <i>Titre</i> CONTROLEUR DE CIRCULATION <i>"Sergocclair"</i> FLOW INDICATOR			Figure - <i>Figure</i> 5870 67		Orifice - <i>Orifice</i> 15 à 50
Toute reproduction est interdite, sans l'autorisation de SNRI					-