

80	Glace Glass	Pyrex Pyrex
79	Volet Shutter	Acier inox Z8 CNDT17.12 Stainless steel AISI 316Ti
5	Boulonnerie Bolting	Acier Classe 10/9 Steel A 193 Gr B7 / A 194 Gr 2H
4	Joint Gasket	Graphite Graphite
2	Bride Flange	Fonte FGS 400-15 Cast Iron A 536 Gr 60.40.18
1	Corps Body	Fonte FGS 400-15 Cast Iron A 536 Gr 60.40.18
REP MARK	DESIGNATION DESIGNATION	MATIERE (AFNOR) MATERIAL (ASTM/AISI)

REFERENCES - REFERENCES

Les nuances ASTM/AISI ne figurent qu'à titre indicatif - *ASTM/AISI materials are not contractual*
 Conditions de service maximum - *Maximum service conditions* : DN65, 16 Bars/110°C
 DN80 à 200, 15 Bars/110°C
 Raccordement - *Connection* : Brides, ISO PN16, type 21, NF-EN 1092-2 (09/97)
 Classe de pression - *Pressure class* : ISO PN16
 Courbe pression / TC - *Pressure / TC curve* : NFE 29.006 (07/83)

OPTIONS - OPTIONS

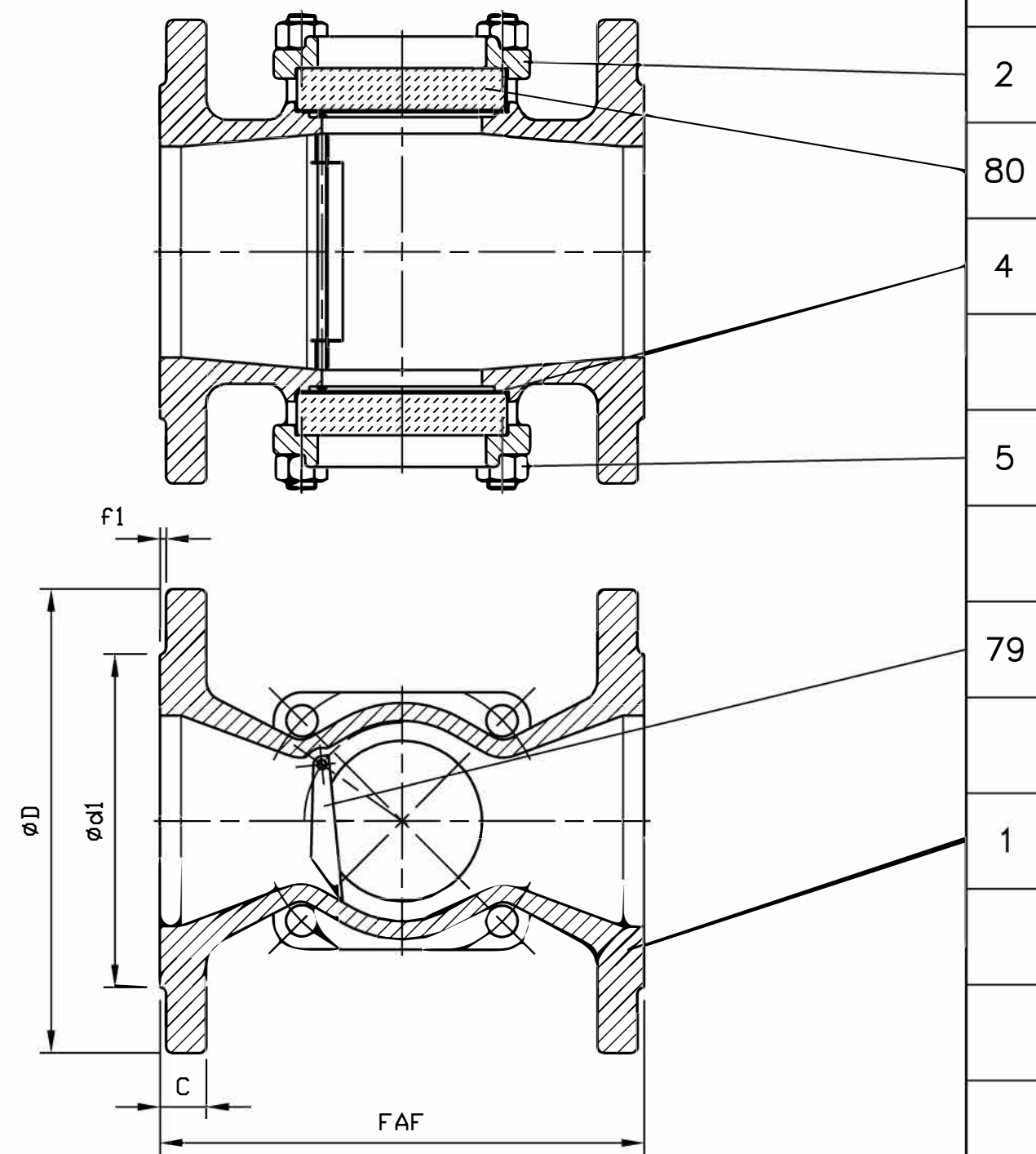

DN	65	80	100	125	150	200
Catégorie suivant DESP - Type in accordance with PED : 97/23/CE	art. 3.3	art. 3.3	art. 3.3	art. 3.3	art. 3.3	art. 3.3
FAF mm	185	210	230	250	280	350
øD / C mm	185/19	200/19	220/19	250/19	285/19	340/20
Nbr/øTrou/øPercage Nbr/øHole/øDrilling mm	4/19/145	8/19/160	8/19/180	8/19/210	8/23/240	12/23/295
ød1 / f1 mm	118/3	132/3	156/3	184/3	211/3	266/3
Masse - Weight kg	10,3	12,5	16,8	21	30	44

A	30.06.03	C. Longuet	A. Lairault	D. Dunoyer	Etablissement du plan/First issue
Indice Index	Date Date	Rédigé Issued by	Vérifié Checked by	Approuvé Approved by	Objet de la modification Modification object
Titre-Title	CONTROLEUR DE CIRCULATION "Sergocclair" FLOW INDICATOR			Figure - Figure	Orifice - Orifice
				5870 07	65 à 200
Toute reproduction est interdite, sans l'autorisation de SNRI					-

