

80	Glacé Glass	Pyrex Pyrex
79	Volet Shutter	Acier inox Z8 CNDT17.12 Stainless steel AISI 316Ti
5	Boulonnerie Bolting	Acier Classe 10/9 Steel A 193 Gr B7 / A 194 Gr 2H
4	Joint Gasket	Graphite Graphite
2	Bride Flange	Acier A 480 CP-M Steel A 216 WCB
1	Corps Body	Fonte FGL 250 Cast Iron A 126 Class B
REP MARK	DESIGNATION DESIGNATION	MATIERE (AFNOR) MATERIAL (ASTM/AISI)

REFERENCES REFERENCES

Les nuances ASTM/AISI ne figurent qu'à titre indicatif - *ASTM/AISI materials are not contractual*  
 Conditions de service maximum - *Maximum service conditions* : DN15 à 32, 10 Bars/110°C  
 DN40 à 50, 8 Bars/110°C  
 Raccordement - *Connection* : Manchon taraudés gaz suivant NFE 03.005 (12/81)  
 Classe de pression - *Pressure class* : ISO PN10  
 Courbe pression / TC - *Pressure / TC curve* : NFE 29.006 (07/83)

OPTIONS - OPTIONS

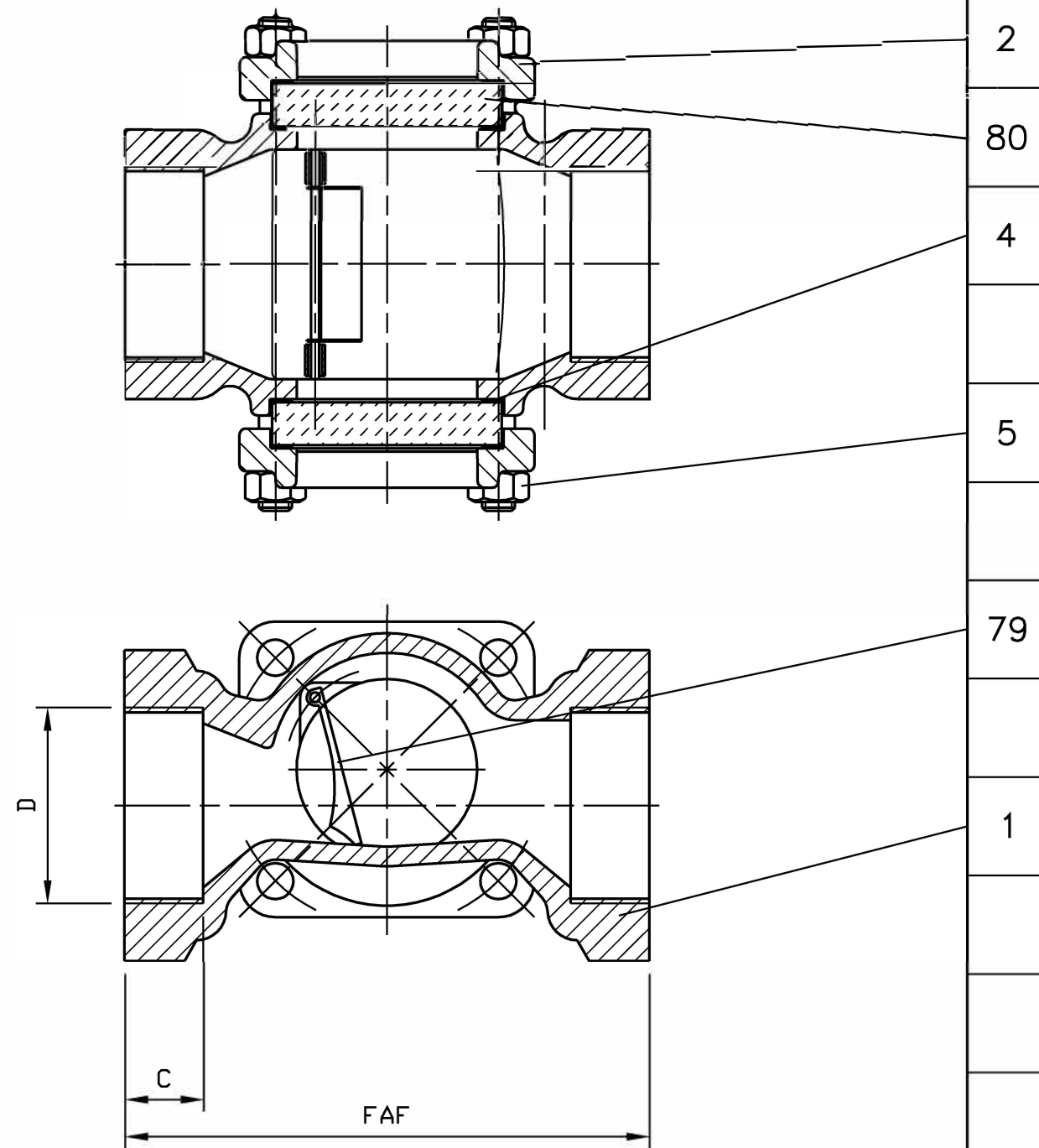

DN	15	20	25	32	40	50
Catégorie suivant DESP - <i>Type in accordance with PED : 97/23/CE</i>	art. 3.3	art. 3.3	art. 3.3	art. 3.3	art. 3.3	art. 3.3
FAF mm	105	105	110	120	140	160
D mm	15x21	20x27	26x34	33x42	40x49	50x60
C mm	13	15	17	19	20	24
Masse - <i>Weight</i> kg	1,5	1,4	1,7	2	3,3	4,2

A	01.07.03	C. Longuet	A. Lairault	D. Dunoyer	Etablissement du plan/First issue
Indice Index	Date Date	Rédigé Issued by	Vérifié Checked by	Approuvé Approved by	Objet de la modification Modification object
Titre - <i>Title</i>	CONTROLEUR DE CIRCULATION "Sergocclair" FLOW INDICATOR			Figure - <i>Figure</i>	Orifice - <i>Orifice</i>
				5867   07	15 à 50
Toute reproduction est interdite, sans l'autorisation de SNRI					-