

44	Axe d'articulation Hinge pin	Acier inox Z 20 C13 Stainless steel AISI 420
43	Levier Hinge lever	Acier A 480 CP-M Steel A 216 Gr WCB
7	Joint corps/couvercle Body/cover gasket	Spiralé inox graphite Stainless steel graphite spiraled
6	Boulonnerie Bolting	Acier classe 10/9 Steel A193 Gr.B7/ A 194 Gr.2H
4	Siège / Portée d'étanchéité Seat / Tightness-seating	Acier A 480 CP-M / 13% Cr Steel A 216 Gr WCB / 13% Cr
3	Obturateur / Portée d'étanchéité (DN150) Disc / Tightness-seating (ND150)	Acier P265GH / 13% Cr Steel A 515 Gr 60 / 13% Cr
3	Obturateur / Portée d'étanchéité Disc / Tightness-seating	Acier inox Z 12 C13 Stainless steel AISI 410
2	Chapeau Bonnet	Acier P295GH Steel A 515 Gr 65
1	Corps Body	Acier A 480 CP-M Steel A 216 Gr WCB
REP MARK	DESIGNATION DESIGNATION	MATIERE (AFNOR) MATERIAL (ASTM/AISI)

REFERENCES - REFERENCES

Les nuances ASTM/AISI ne figurent qu'à titre indicatif - *ASTM/AISI materials are not contractual*
 Construction - *Construction* : NFE 29.373 (12/84)
 Raccordement - *Connection* : Brides, PN64, svt NFE 29.226 (06/82)
 Classe de pression - *Pressure class* : PN64
 Essais - *Testing* : NFE 29.311 (06/82), taux d'étanchéité 2
 Courbe pression / TC - *Pressure / TC curve* : NFE 29.005 (91), ISO 7005-1 (04/92)

OPTIONS - OPTIONS

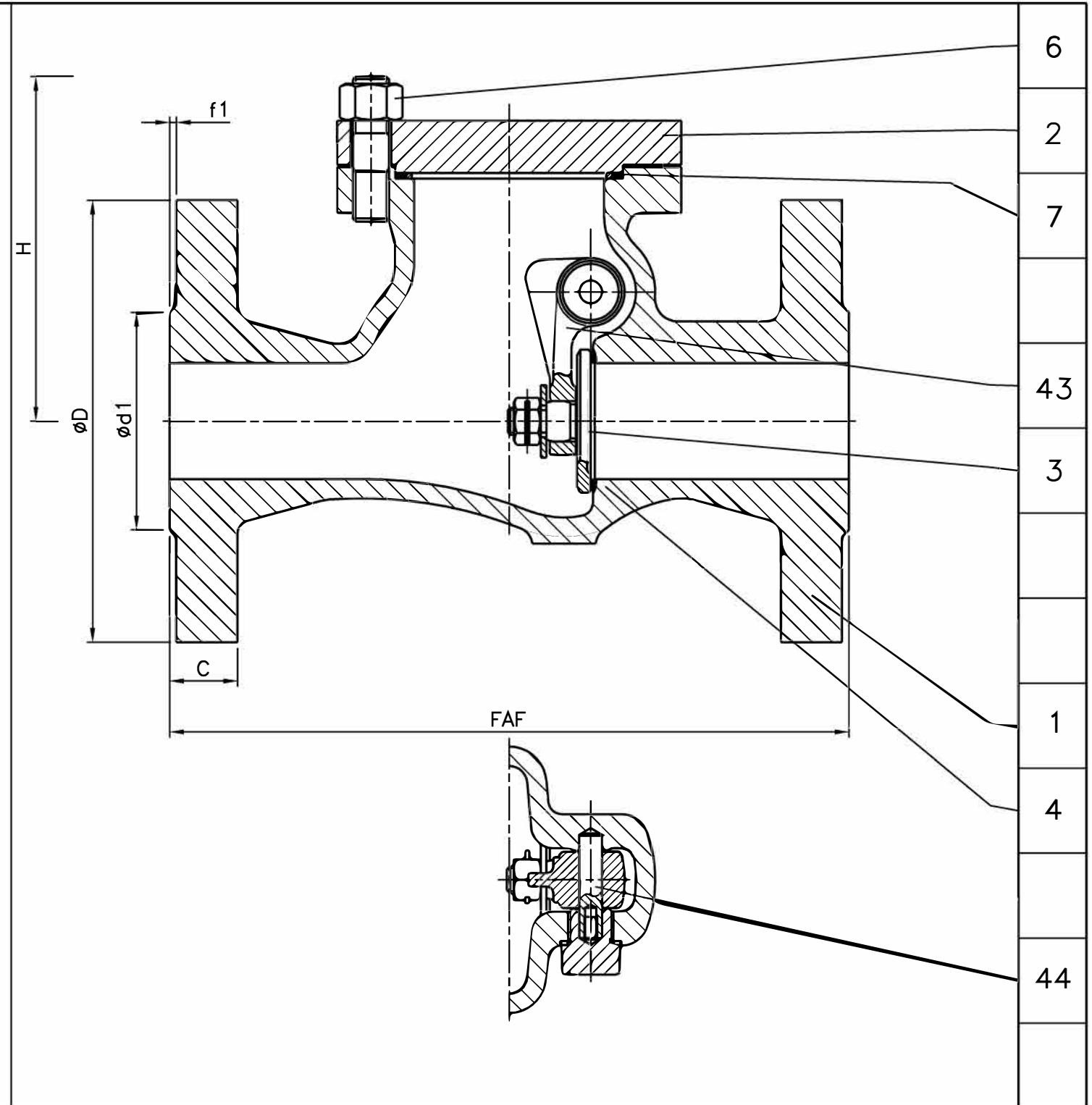

DN	40	50	80	100	125	150		
Catégorie suivant DESP - <i>Type in accordance with PED : 97/23/CE</i>	C2	C2	C2	C2	C3	C3		
FAF mm	260	300	380	430	500	550		
øD/C mm	170/26	180/26	215/26	250/30	295/34	345/36		
Nbr/øTrou/øPerçage Nbr/øHole/øDrilling mm	4/22/125	4/22/135	8/22/170	8/26/200	8/30/240	8/33/280		
ød1/f1 mm	88/3	102/3	133/3	158/3	184/3	212/3		
H mm	152	152	170	205	205	246		
Kv	78	138	552	950	1466	2155		
Masse - <i>Weight</i> kg	15	19	34	50	62	96		

A	29.10.04	C. Longuet	A. Lairault	D. Dunoyer	Etablissement du plan/First issue
Indice Index	Date Date	Rédigé Issued by	Vérifié Checked by	Approuvé Approved by	Objet de la modification Modification object
Titre-Title	CLAPET DE NON RETOUR A BATTANT "Uniclap" SWING CHECK VALVE			Figure - Figure	Orifice - Orifice
				4348 07	40 à 150
Toute reproduction est interdite, sans l'autorisation de SNRI					-

