

44	Axe d'articulation <i>Hinge pin</i>	Laiton Cu Zn40 <i>Brass</i>
43	Battant <i>Hinge lever</i>	Bronze Cu Sn5 Pb5 Zn5 <i>Bronze B145 Gr.4A</i>
3	Clapet / Portage <i>Disc / Disc face</i>	Bronze Cu Sn5 Pb5 Zn5 <i>Bronze B145 Gr.4A</i>
4	Siege / Portage <i>Seat / Seating face</i>	Bronze Cu Sn5 Pb5 Zn5 <i>Bronze B145 Gr.4A</i>
1	Corps <i>Body</i>	Bronze Cu Sn5 Pb5 Zn5 <i>Bronze B145 Gr.4A</i>
REP MARK	DESIGNATION <i>DESIGNATION</i>	MATIERE (AFNOR) <i>MATERIAL (ASTM/AISI)</i>

REFERENCES - REFERENCES

Les nuances ASTM/AISI ne figurent qu'à titre indicatif - *ASTM/AISI materials are not contractual*  
 Construction - *Construction* : -  
 Raccordement - *Connection* : Brides, ISO PN25, type 21-B, NFE 29.207 (04/86)  
 Classe de pression - *Pressure class* : ISO PN25  
 Essais - *Testing* : NFE 29.311 (06/82), taux d'étanchéité 2  
 Plage admissible T°C - *Admissible range T°C* : -10°C +260°C

OPTIONS - OPTIONS

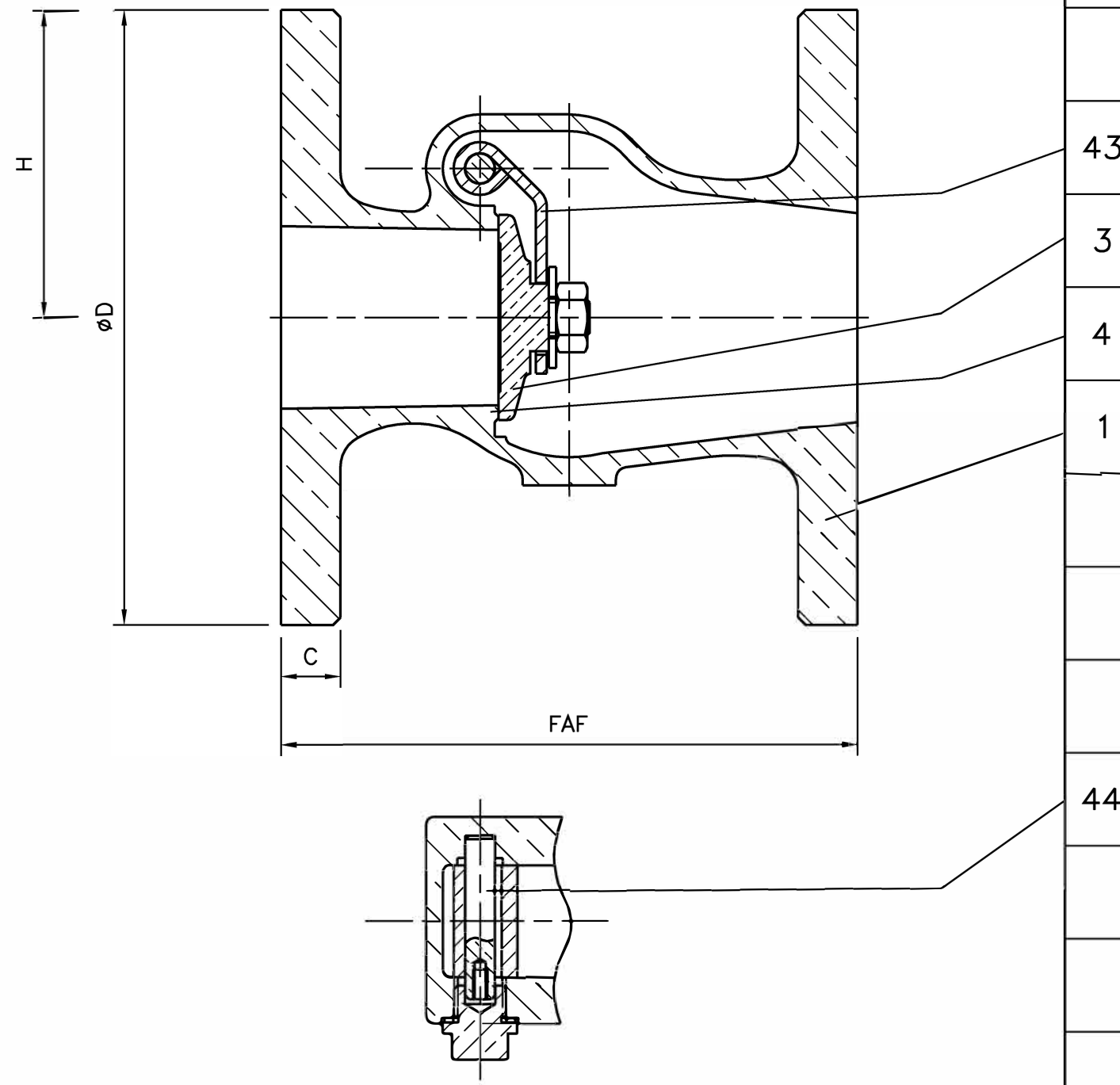

DN	40	50							
Catégorie suivant DESP - <i>Type in accordance with PED : 97/23/CE</i>	art. 3.3	C1							
FAF mm	140	155							
øD/C mm	150/18	165/20							
Nbr/øTrou/øPerçage <i>Nbr/øHole/øDrilling</i>	4/18/110	4/18/125							
H mm	48	55							
Masse - <i>Weight</i> kg	5,5	7							

B	14.01.03	C. Longuet	A. Lairault	D. Dunoyer	Mise à jour / Up to date
A	16.10.02	C. Longuet	A. Lairault	D. Dunoyer	Etablissement du plan/First issue
Indice <i>Index</i>	Date <i>Date</i>	Rédigé <i>Issued by</i>	Vérifié <i>Checked by</i>	Approuvé <i>Approved by</i>	Objet de la modification <i>Modification object</i>

CLAPET DE NON RETOUR A BATTANT  
 "Uniclap"  
 SWING CHECK VALVE

Figure - *Figure* 4283 | 01 | Orifice - *Orifice* 40 à 50

Toute reproduction est interdite, sans l'autorisation de SNRI -

