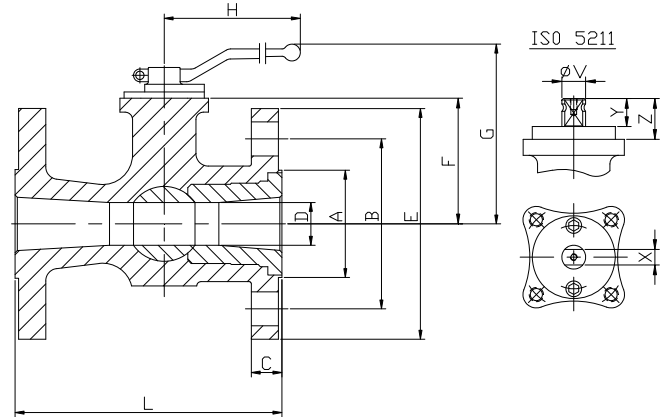
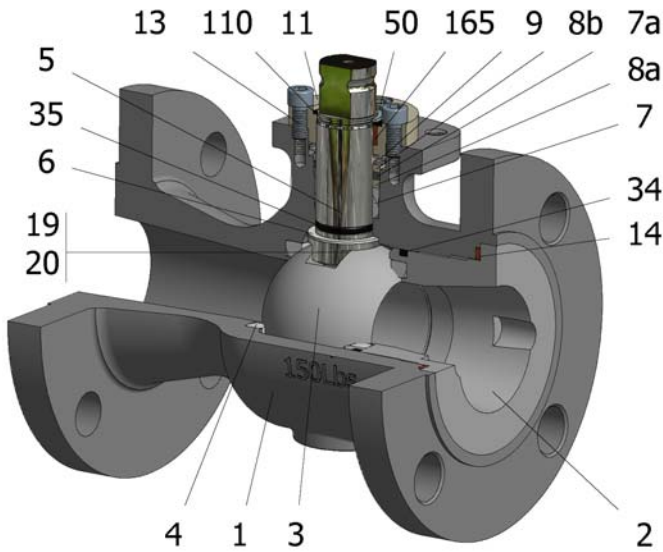

FIG.ZRB 19 SSGVV CL150 1/2"-12"



Position	Description	Material
01	Body 1	C.S. A352 LCC
02	Body 2	C.S. A350 LF2
03	Ball	S.S. A351 CF8M
04	Seat	PTFE+CG
05	Stem	S.S. AISI 316
06	Stem seal	PTFE+CG
07	Stem packing 1	PTFE+CG
07a	Stem packing 2	Graphite
08a	Gland packing	S.S. AISI 316
08b	Gland packing 1	S.S. AISI 316
09	Spring washer	S.S. AISI 301
11	Cover	S.S. A351 CF8M
13	Cover bolt	S.S. (316)
14	Body seal 1	Graphite
16	Handle	WCB
17	Handle bolt	1.045(8.8)
19	Spring	S.S. AISI 316
20	Antistatic ball	S.S. AISI 316
34	Body seal 2	FKM
35	O ring stem	FKM
50	Subjection ring	S.S. AISI 304
110	Subjection ring seal	S.S. AISI 316 Nitrided
165	Stem bearing	PTFE+FG

General features

- Floating ball.
- End entry.
- Reduced bore.
- Soft seat.
- Bidirectional.
- TA-LUFT.
- Anti Blow out proof stem.
- Autoadjustable packing.
- Anti static device.
- Self-cavity pressure relief.

Standards

- Top flange ISO 5211
- Flanges ANSI B16.5
- Face to face ANSI B16.10
- Testing API 598, API 6D, BS 6755-1
- Design AP 6D, B16.34
- Materials according to NACE MR0175

Official approvals

- CERTIFICATE FIRE SAFE
- TA-LUFT VDI 2440
- ISO 15848-1
- API 6D.
- ATEX 2014/34/EU
- PED 2014/68/EU
- SIL 3 CAPABLE
- EN 161/EN ISO 23553-1

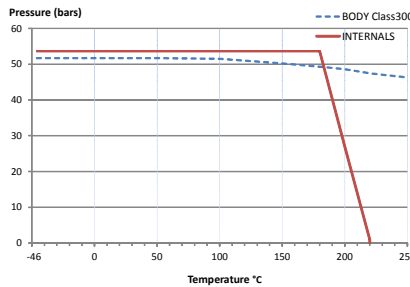

PEKOS GROUP CERTIFICATES:

ISO 9001-2008 / 2014/68/EU / API-6D



DIMENSIONS & Technical information

DN	CL	D	L	E	A	B	C	F	H	G	V	X	Y	Z	n x d	ISO 5211	Torque	MAST	Weight
1"	150	20	127	110	51	79	13	47	185	110	14	11	11	13,5	4 x 16	F05	13	42,4	3,4
1 1/2"	150	32	165	125	73	98	16	57	185	120	18	14	17	19,5	4 x 16	F05	28	92,2	5,5
2"	150	40	178	150	92	121	17	75	293	147	22	17	20	30	4 x 19	F07	38	244,3	9,0
3"	150	65	203	190	127	152	21	96	293	168	22	17	20	30	4 x 19	F07	74	244,3	17,5
4"	150	80	229	230	157	191	25	114	350	204	28	22	22	40	8 x 19	F10	124	509,7	25,8
6"	150	111	267	280	216	241	26	149	740	261	36	27	35	50	8 x 22	F12	317	1047,2	46,3
8"	150	144	292	345	270	299	30	173	740	285	36	27	35	50	8 x 22	F12	480	1047,2	78,0

** Depending on service conditions.

* Dimensions are in mm.

* Torque & MAST are in Nm

* Weight is in Kilogram

* Torque values have been measured ΔP at maximum rating at room temperature

DS-1815
Rev.7