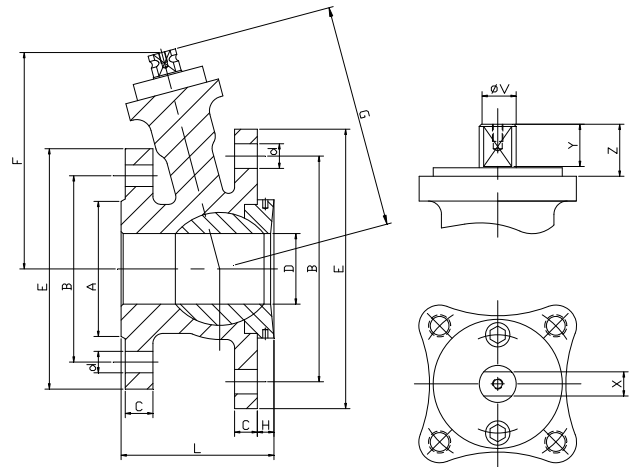
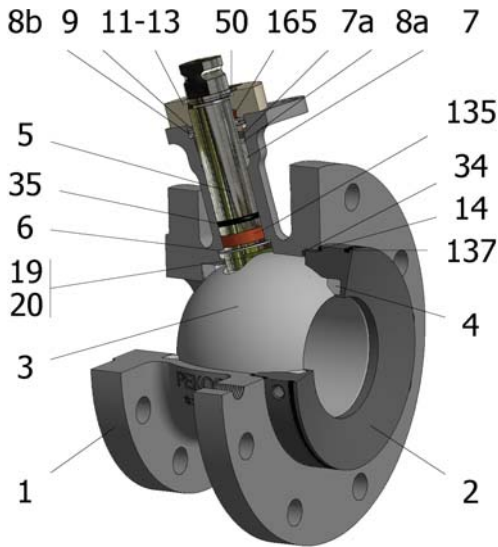

FIG.ZI 56 TTTVV PN16 DN40/150



Position	Description	Material
01	Body 1	S.S. 1.4408
02	Body 2	S.S. 1.4401
03	Ball	S.S. 1.4408
04	Seat	PTFE
05	Stem	S.S. 1.4401
06	Stem seal	PTFE+FG
07	Stem packing 1	PTFE
07a	Stem packing 2	Graphite
08a	Gland packing 1	S.S. 1.4401
08b	Gland packing 2	S.S. 1.4401
09	Spring washer	S.S. 1.4310
11	Cover	S.S. 1.4408
13	Cover bolt	A4-70
14	Body seal 1	PTFE
19	Spring	S.S. 1.4401
20	Antistatic ball	S.S. 1.4401
34	Body seal 2	FKM
35	O ring stem	FKM
50	Subjection ring	S.S. 1.4021
135	Stem tip	PTFE+CG
137	O ring body 2	FKM
165	Stem bearing	PTFE+FG

General features

- Floating ball.
- End entry.
- Full bore.
- Soft seat.
- Bidirectional.
- TA-LUFT.
- Anti Blow out proof stem.
- Autoadjustable packing.
- Anti static device.
- Self-cavity pressure relief.

Standards

- Top flange ISO 5211
- Flanges EN 1092-01
- Testing EN-12266, ISO 5208
- Design EN-12516, ISO 17292

Official approvals

- TA-LUFT VDI 2440
- ISO 15848-1
- ATEX 2014/34/EU
- PED 2014/68/EU
- SIL 3 CAPABLE

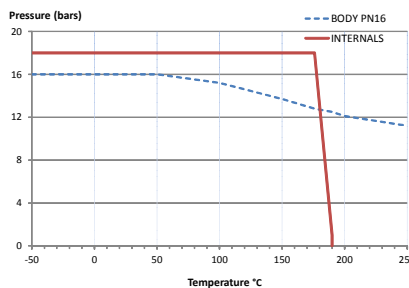

PEKOS GROUP CERTIFICATES:
ISO 9001-2008 / 2014/68/EU /API-6D



DIMENSIONS & Technical information

DN	PN	D	L	E	A	B	C	F	H	G	V	X	Y	Z	n x d	ISO 5211	Torque	MAST	Weight
40	16	40	116	150/185	88	110/145	26/18	136	20	140	22	17	20	30	4/8 x 18/18	F07	31	250,4	11
50	16	50	116	165/200	102	125/160	26/18	136	20	140	22	17	20	30	4/8 x 18/18	F07	46	250,4	12
65	16	65	133	185/220	122	145/180	26/20	151	20	156	22	17	20	30	8/8 x 18/18	F07	55	250,4	15
80	16	80	144	200/250	138	160/210	26/18	188	25	195	28	22	22	40	8/8 x 18/18	F10	85	522,5	21
100	16	100	169	220/285	158	180/240	26/18	201	25	209	28	22	22	40	8/8 x 18/22	F10	110	522,5	28
125	16	125	259	250/340	188	210/295	22/21	239	30	247	36	27	35	50	8/12 x 18/22	F12	240	1073,4	70
150	16	150	282	285/405	212	240/355	22/23	257	30	266	36	27	35	50	8/12 x 22/26	F12	380	1073,4	74,5

** Depending on service conditions.

* Dimensions are in mm.

* Torque & MAST are in Nm.

* Weight is in Kilogram

* Torque values have been measured ΔP at maximum rating at room temperature

DS-2032
Rev.3