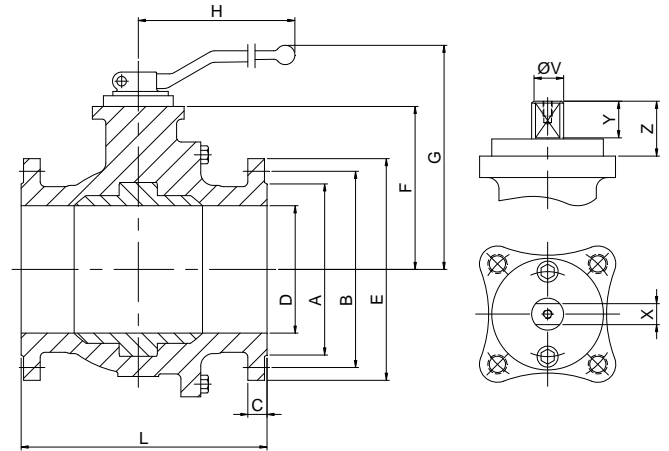
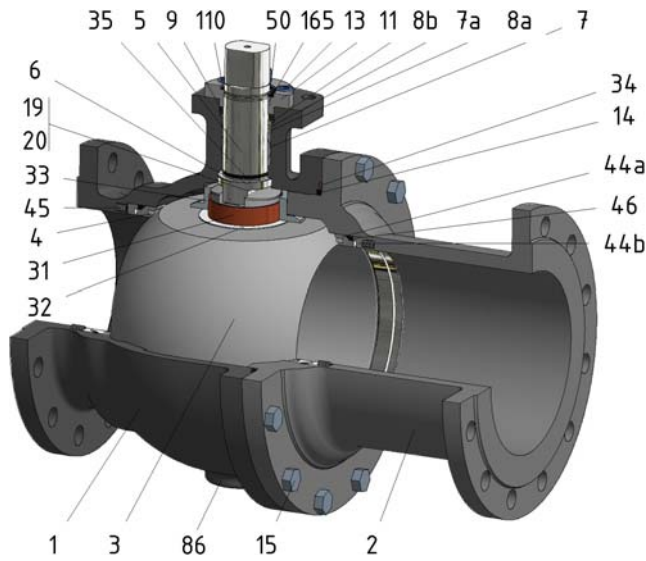

FIG.ZGS 29 SSSGV PN40 DN150-300 F1



Position	Description	Material
01	Body 1	C.S. 1.6220
02	Body 2	C.S. 1.0352
03	Ball	S.S. 1.4408
04	Seat	PTFE+CG
05	Stem	D.S.S. 1.4462
06	Stem seal	PTFE+CG
07	Stem packing 1	PTFE+CG
07a	Stem packing 2	Graphite
08a	Gland packing 1	S.S. 1.4401
08b	Gland packing 2	S.S. 1.4401
09	Spring washer	S.S. 1.4310
11	Cover	S.S. 1.4408
13	Cover bolt	A4-70
14	Body seal 1	PTFE+CG
15	Body bolt	A2-70
16	Handle	WCB
17	Handle bolt	1.045(8.8)
19	Spring	Inconel X750
20	Antistatic ball	Inconel 625
23	Handle pin	S.S. 1.4021
24	Lengthening handle	S.S. 1.0254
31	Bearing	PTFE
32	Bearing disk	PTFE+FG
33	Support bearing	S.S. 1.4401
34	Body seal 2	Graphite
35	O ring stem	FKM
44a	Ring seat 1	S.S. 1.4401
44b	Ring seat 2	S.S. 1.4401
45	Spring seat	Inconel X750
46	Seat seal	Graphite
50	Subjection ring	S.S. 1.4021
86	Drain plug	C.S. A350 LF2
86a	Vent plug	C.S. A350 LF2
110	Subjection ring seal	S.S. 1.4401 Nitrided
165	Stem bearing	PTFE+FG

General features

- Full trunnion.
- Split body.
- Full bore.
- Soft seat.
- Bidirectional.
- Spring loaded seat system.
- Anti Blow out proof stem.
- Autoadjustable packing.
- Anti static device.
- Self-cavity pressure relief.
- Double Block and Bleed.

Standards

- Top flange ISO 5211
- Flanges EN 1092-01
- Face to face EN 558
- Testing EN-12266, ISO 5208
- Design EN-12516, ISO 17292

Official approvals

- CERTIFICATE FIRE SAFE
- TA-LUFT VDI 2440
- ISO 15848-1
- ATEX 2014/34/EU
- PED 2014/68/EU
- SIL 3 CAPABLE

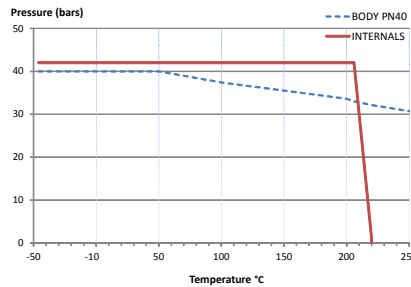

PEKOS GROUP CERTIFICATES:
ISO 9001-2008 / 2014/68/EU / API-6D



DIMENSIONS & Technical information

DN	PN	D	L	E	A	B	C	F	H	G	V	X	Y	Z	n x d	ISO 5211	Torque	MAST	Weight
150	40	150	480	300	218	250	28	176	740	285	36	27	35	50	8 x 26	F12	875	2356,2	110,0
200	40	200	600	375	285	320	34	245	750	362	48	36	40	63	12 x 30	F14	1364	5585,0	194,0
250	40	250	730	450	345	385	38	285	-	-	48	36	40	63	12 x 33	F14	1794	5585,0	335,0
300	40	300	850	515	410	450	42	329	-	-	48	36	40	63	16 x 33	F14	2187	5585,0	491,0

** Depending on service conditions. * Dimensions are in mm. * Torque & MAST are in Nm. * Weight is in Kilogram

* Torque values have been measured ΔP at maximum rating at room temperature

DS-3514
Rev.3