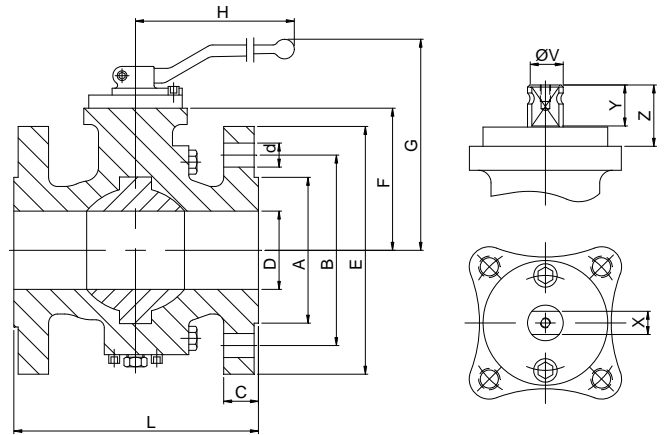
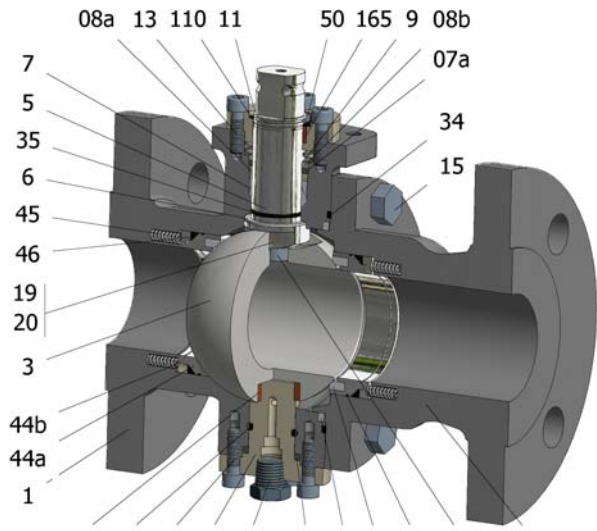

FIG.ZGS 24 SSSGV PN16 DN50-100 F1



127 148 163 128 86 109 14 4 108 167

Position	Description	Material
01	Body 1	C.S. 1.0352
02	Body 2	C.S. 1.0352
03	Ball	S.S. 1.4408
04	Seat	PTFE+CG
05	Stem	D.S.S. 1.4462
06	Stem seal	PTFE+CG
07	Stem packing 1	PTFE+CG
07a	Stem packing 2	Graphite
08	Gland packing	S.S. 1.4401
09	Spring washer	S.S. 1.4310
11	Cover	S.S. 1.4401
13	Cover bolt	A4-70
14	Body seal 1	PTFE+CG
15	Body bolt	A2-70
16	Handle	WCB
17	Handle bolt	1.045(8.8)
19	Spring	Inconel X750
20	Antistatic ball	Inconel 625
34	Body seal 2	Graphite
35	O ring stem	FKM
44a	Ring seat 1	S.S. 1.4401
44b	Ring seat 2	S.S. 1.4401
45	Spring seat	Inconel X750
46	Seat seal	Graphite
50	Subjection ring	S.S. 1.4301
86	Drain plug	S.S. 1.4401
108	O ring seat	FKM
109	Cover seal	Graphite
110	Subjection ring seal	S.S. 1.4401 Nitrided
127	Stem bearing	MU
128	Body cover 2	C.S. 1.0352
148	O ring cover	FKM
163	Body cover 2 bolt	A4-70
165	Stem bearing	PTFE+FG
167	Stem guide bolt	A2-70 Nitrided

General features

- Full trunnion.
- Split body.
- Full bore.
- Soft seat.
- Bidirectional.
- Spring loaded seat system.
- Anti Blow out proof stem.
- Autoadjustable packing.
- Anti static device.
- Self-cavity pressure relief.
- Double Block and Bleed.

Standards

- Top flange ISO 5211
- Flanges EN 1092-01
- Face to face EN 558
- Testing EN-12266, ISO 5208
- Design EN-12516, ISO 17292

Official approvals

- CERTIFICATE FIRE SAFE
- TA-LUFT VDI 2440
- ISO 15848-1
- ATEX 2014/34/EU
- PED 2014/68/EU
- SIL 3 CAPABLE

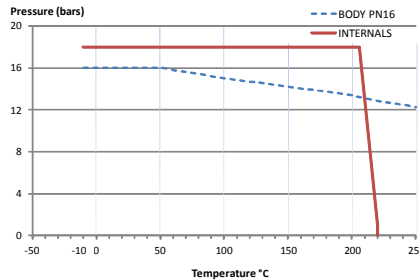

PEKOS GROUP CERTIFICATES:
ISO 9001-2008 / 2014/68/EU / API-6D



DIMENSIONS & Technical information

DN	PN	D	L	E	A	B	C	F	H	G	V	X	Y	Z	n x d	ISO 5211	Torque	MAST	Weight
50	16	50	230	165	102	125	18	84	293	154	22	17	20	30	4 x 18	F07	84	549,6	10,0
80	16	80	310	200	138	160	20	114	350	207	28	22	22	40	8 x 18	F10	203	1146,9	22,0
100	16	100	350	220	158	180	20	128	350	221	28	22	22	40	8 x 18	F10	344	1146,9	32,0

** Depending on service conditions.

* Dimensions are in mm.

* Torque & MAST are in Nm.

* Weight is in Kilogram

* Torque values have been measured ΔP at maximum rating at room temperature

DS-2425
Rev.2