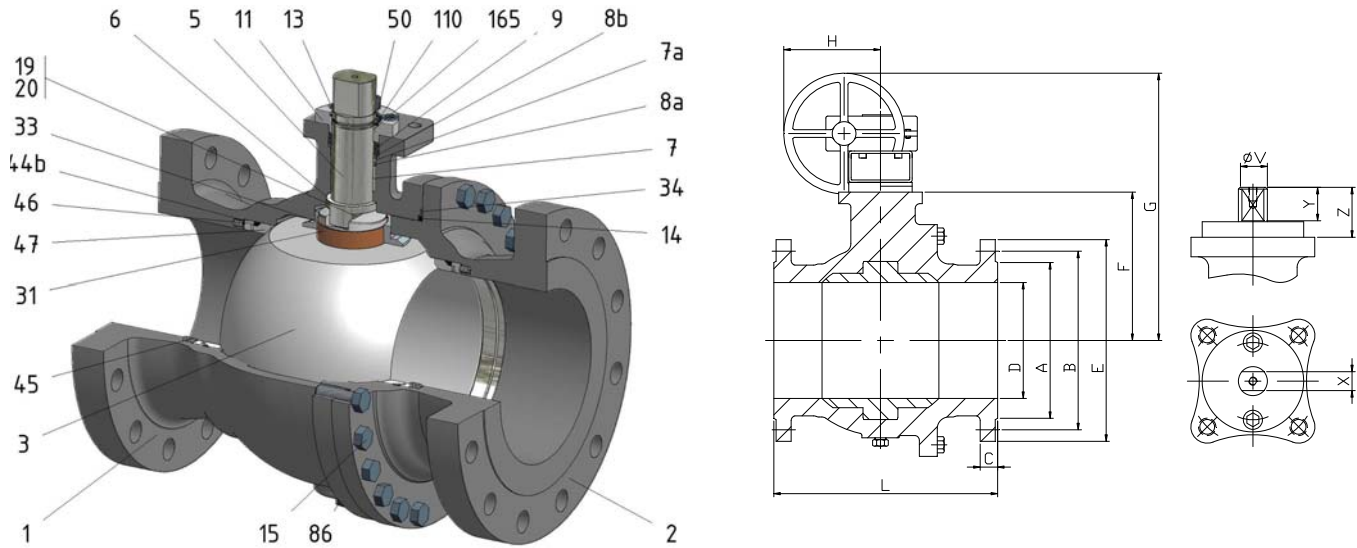

FIG.ZGMS 34 CGGG CL300 6"-12" RF



Position	Description	Material
01	Body 1	C.S. A216 WCC
02	Body 2	C.S. A216 WCC
03	Ball	S.S. F316+Cr-Carbide
05	Stem	XM-19
06	Stem seal	S.S. AISI 316 Nitrided
07	Stem packing 1	Graphite
07a	Stem packing 2	Graphite
08a	Gland packing 1	S.S. AISI 316
08b	Gland packing 2	S.S. AISI 316
09	Spring washer	Inconel X718
11	Cover	S.S. A351 CF8M
13	Cover bolt	S.S. (316)
14	Body seal 1	Graphite
15	Body bolt	A193 B7M
19	Spring	S.S. AISI 316
20	Antistatic ball	S.S. AISI 316
31	Bearing	Carbongraphite
33	Support bearing	S.S. AISI 316
34	Body seal 2	Graphite
44b	Ring seat 2	S.S. AISI 316
45	Spring seat	Inconel X750
46	Seat seal	Graphite
47	Metal seat	AISI 316+Cr-Carbide
50	Subjection ring	S.S. AISI 420
86	Drain plug	C.S. A350 LF2
86a	Vent plug	C.S. A350 LF2
110	Subjection ring seal	S.S. AISI 316 Nitrided
165	Stem bearing	Carbongraphite

General features

- Full trunnion.
- Split body.
- Full bore.
- Metal to Metal.
- Bidirectional.
- Spring loaded seat system.
- Anti Blow out proof stem.
- Autoadjustable packing.
- Anti static device.
- Self-cavity pressure relief.
- Double Block and Bleed.

Standards

- Top flange ISO 5211
- Flanges ANSI B16.5
- Face to face ANSI B16.10
- Testing API 598, API 6D, BS 6755-1
- Design API 6D, B16.34
- Materials according to NACE MR0175

Official approvals

- CERTIFICATE FIRE SAFE
- TA-LUFT VDI 2440
- ISO 15848-1
- ATEX 2014/34/EU
- API 6D.
- PED 2014/68/EU
- SIL 3 CAPABLE

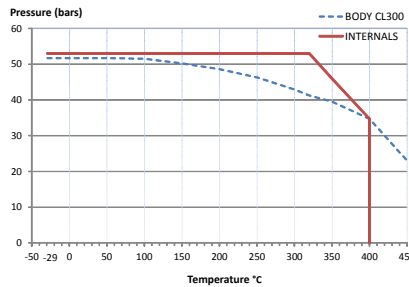

PEKOS GROUP CERTIFICATES:

ISO 9001-2008 / 2014/68/EU / API-6D



DIMENSIONS & Technical information

DN	CL	D	L	E	A	B	C	F	H	G	V	X	Y	Z	n x d	ISO 5211	Torque	MAST	Weight
6"	300	150	403	320	216	270	38	176	436	554	36	27	35	44	12 x 22	F14-1	1788	1989,7	117
8"	300	201	502	380	270	330	43	245	461	630	48	36	40	63	12 x 25	F16-1	2787	4716,3	197
10"	300	252	568	445	324	387	49	285	461	670	48	36	40	63	16 x 29	F16-1	3629	4716,3	284
12"	300	303	648	520	381	451	52	329	563	768	48	36	40	63	16 x 32	F16-1	4412	4716,3	400

** Depending on service conditions.

* Dimensions are in mm.

* Torque & MAST are in Nm

* Weight is in Kilogram

* Torque values have been measured ΔP at maximum rating at room temperature

DS-787
 Rev.17