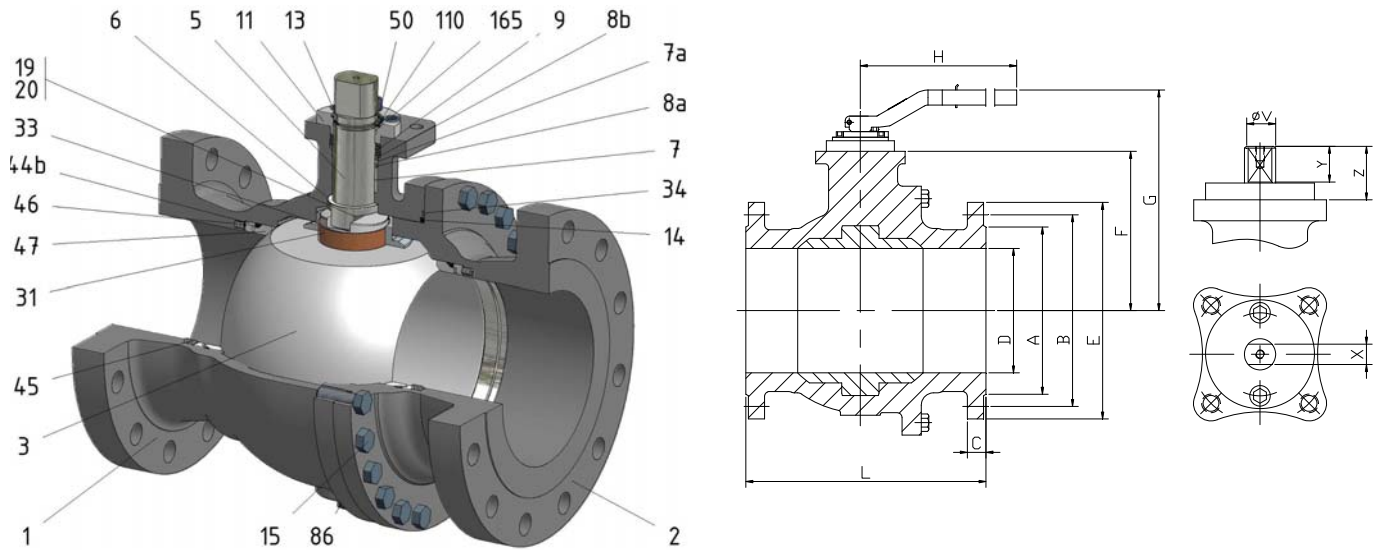

FIG.ZGMS 04 CGGG PN25 DN150/300 F5



Position	Description	Material
01	Body 1	C.S. 1.0619
02	Body 2	C.S. 1.0619
03	Ball	S.S. 1.4401+Cr-Carbide
05	Stem	S.S. 1.4401
6	Stem seal	S.S. 1.4401 Nitrided
07	Stem packing 1	Graphite
08	Gland packing	S.S. 1.4401
09	Spring washer	S.S. 1.4310
11	Cover	S.S. 1.4408
13	Cover bolt	A4-70
14	Body seal 1	Graphite
15	Body bolt	A2-70
16	Handle	WCB
17	Handle bolt	1.045(8.8)
19	Spring	S.S. 1.4401
20	Antistatic ball	S.S. 1.4401
23	Handle pin	S.S. 1.4021
24	Lengthening handle	S.S. 1.0254
31	Bearing	Carbongraphite
33	Support bearing	S275JR+ENP
34	Body seal 2	Graphite
44a	Ring seat 1	S.S. 1.4401
45	Spring seat	Inconel X750
46	Seat seal	Graphite
47	Metal seat	1.4401+Cr-Carbide
50	Subjection ring	S.S. 1.4301
110	Subjection ring seal	S.S. 1.4401 Nitrided
165	Stem bearing	Carbongraphite

General features

- Guided ball.
- Split body.
- Full bore.
- Metal to Metal.
- Bidirectional.
- Spring loaded seat system.
- Anti Blow out proof stem.
- Autoadjustable packing.
- Anti static device.
- Self-cavity pressure relief.

Standards

- Top flange ISO 5211
- Flanges EN 1092-01
- Face to face EN-12982
- Testing EN-12266, ISO 5208
- Design EN-12516, ISO 17292

Official approvals

- CERTIFICATE FIRE SAFE
- TA-LUFT VDI 2440
- ISO 15848-1
- ATEX 2014/34/EU
- PED 2014/68/EU
- SIL 3 CAPABLE

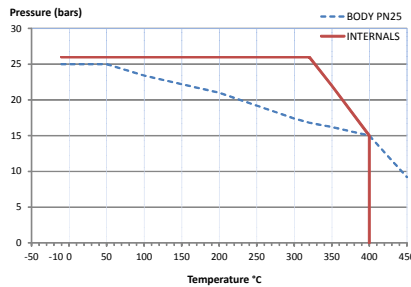

PEKOS GROUP CERTIFICATES:
ISO 9001-2008 / 2014/68/EU / API-6D



DIMENSIONS & Technical information

DN	PN	D	L	E	A	B	C	F	H	G	V	X	Y	Z	n x d	ISO 5211	Torque	MAST	Weight
150	25	150	350	300	218	250	28	175	740	284	36	27	35	50	8 x 26	F12	1256	1073,4	83,0
200	25	200	400	360	278	310	30	245	750	362	48	36	40	63	12 x 26	F14	1959	2544,3	147,0
250	25	250	450	425	335	370	32	285	-	-	48	36	40	63	12 x 30	F14	2614	2544,3	254,0
300	25	300	500	485	395	430	34	336	-	-	48	36	40	63	16 x 30	F14	3221	2544,3	372,0

** Depending on service conditions.

* Dimensions are in mm.

* Torque & MAST are in Nm.

* Weight is in Kilogram

* Torque values have been measured ΔP at maximum rating at room temperature

DS-1356

Rev.4