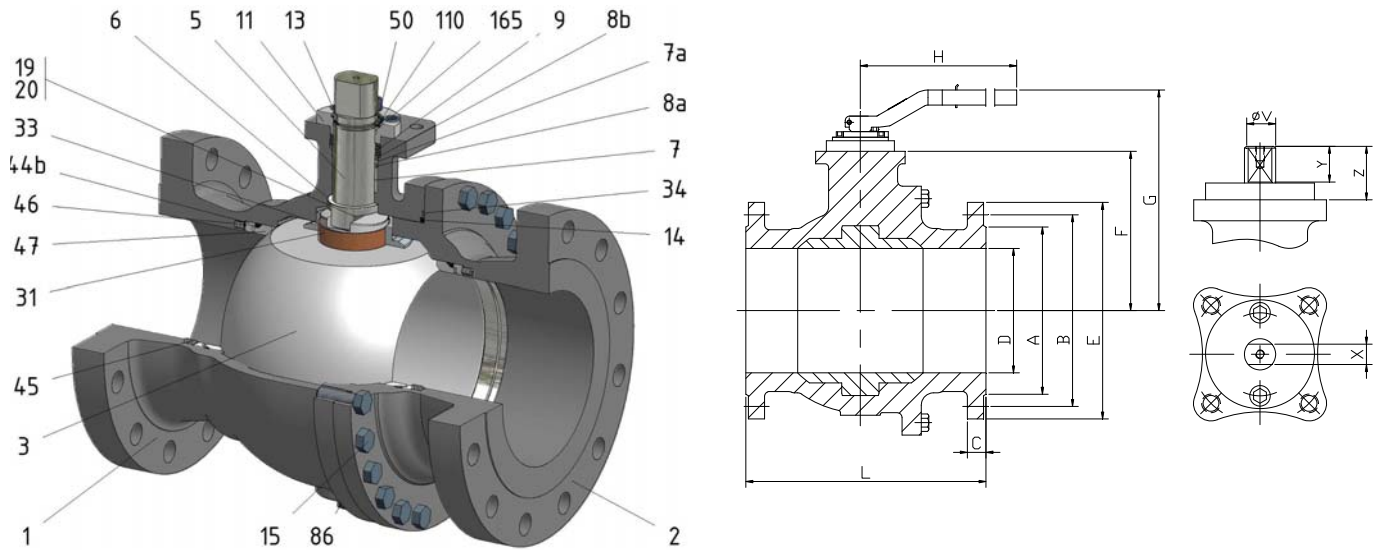

FIG.ZGMS 04 CGGG PN16 DN150/300 F5



Position	Description	Material
01	Body 1	C.S. 1.0619
02	Body 2	C.S. 1.0619
03	Ball	S.S. 1.4401+Cr-Carbide
05	Stem	XM-19
6	Stem seal	S.S. 1.4401 Nitrided
07	Stem packing 1	Graphite
07a	Stem packing 2	Graphite
08a	Gland packing 1	S.S. 1.4401
08b	Gland packing 2	S.S. 1.4401
09	Spring washer	Inconel X718
11	Cover	S.S. 1.4408
13	Cover bolt	A4-70
14	Body seal 1	Graphite
15	Body bolt	A2-70
16	Handle	WCB
17	Handle bolt	1.045(8,8)
19	Spring	Inconel X750
20	Antistatic ball	Inconel X718
23	Handle pin	S.S. 1.4021
24	Lengthening handle	S.S. 1.0254
31	Bearing	Carbongraphite
33	Support bearing	S.S. 1.4401
34	Body seal 2	Graphite
44a	Ring seat 1	S.S. 1.4401
45	Spring seat	Inconel X750
46	Seat seal	Graphite
47	Metal seat	1.4401+Cr-Carbide
50	Subjection ring	S.S. 1.4021
86	Drain plug	C.S. A350 LF2
110	Subjection ring seal	S.S. 1.4401 Nitrided
165	Stem bearing	Carbongraphite

General features

- Full trunnion.
- Split body.
- Full bore.
- Metal to Metal.
- Bidirectional.
- Spring loaded seat system.
- Anti Blow out proof stem.
- Autoadjustable packing.
- Anti static device.
- Self-cavity pressure relief.
- Double Block and Bleed.

Standards

- Top flange ISO 5211
- Flanges EN 1092-01
- Face to face EN 558
- Testing EN-12266, ISO 5208
- Design EN-12516, ISO 17292

Official approvals

- CERTIFICATE FIRE SAFE
- TA-LUFT VDI 2440
- ISO 15848-1
- ATEX 2014/34/EU
- PED 2014/68/EU
- SIL 3 CAPABLE

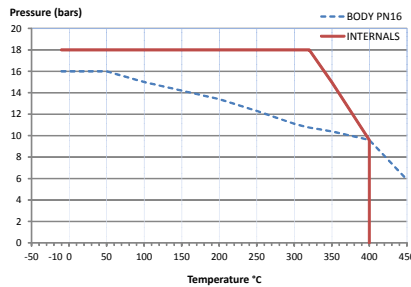

PEKOS GROUP CERTIFICATES:
ISO 9001-2008 / 2014/68/EU / API-6D



DIMENSIONS & Technical information

DN	PN	D	L	E	A	B	C	F	H	G	V	X	Y	Z	n x d	ISO 5211	Torque	MAST	Weight
150	16	150	350	285	212	240	22	176	740	285	36	27	35	50	8 x 22	F12	1065	1989,7	75,0
200	16	200	400	340	268	295	24	245	750	354	48	36	40	63	12 x 22	F14	1660	4716,3	134,0
250	16	250	450	405	320	355	26	285	-	-	48	36	40	63	12 x 26	F14	2245	4716,3	228,0
300	16	300	500	460	378	410	28	329	-	-	48	36	40	63	12 x 26	F14	2793	4716,3	321,0

** Depending on service conditions.

* Dimensions are in mm.

* Torque & MAST are in Nm.

* Weight is in Kilogram

* Torque values have been measured ΔP at maximum rating at room temperature

DS-2257
Rev.3