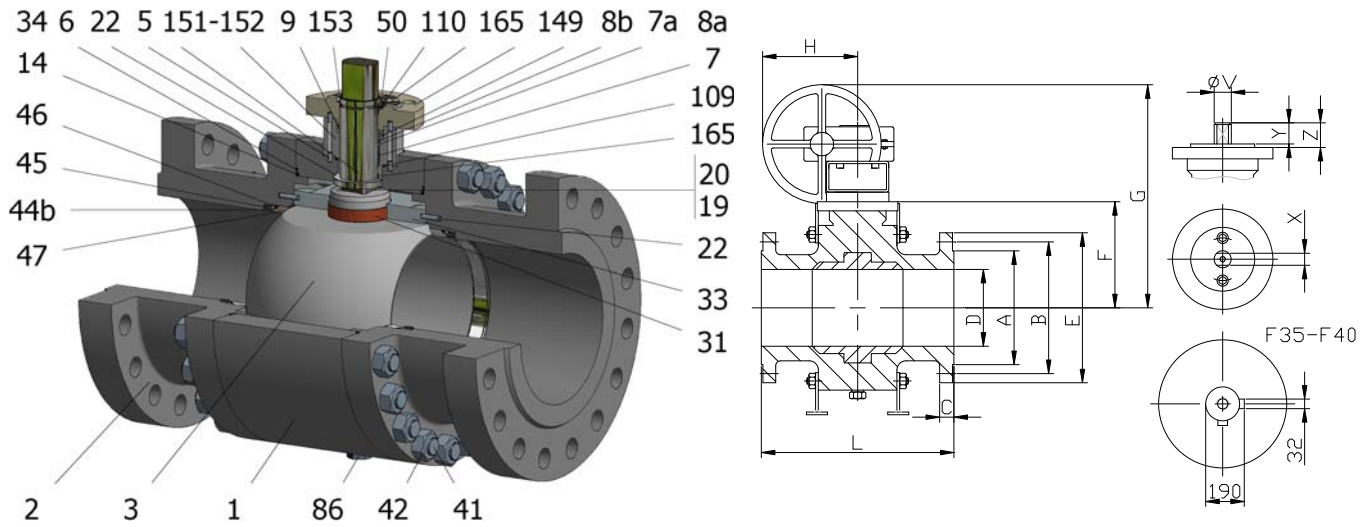

FIG.ZGKMS 26 CGGG PN100 DN100/350 F2



| Position | Description | Material |
|----------|----------------------|------------------------|
| 01 | Body 1 | S.S. 1.4401 |
| 02 | Body 2 | S.S. 1.4401 |
| 03 | Ball | S.S. 1.4401+Cr-Carbide |
| 05 | Stem | XM-19 |
| 06 | Stem seal | S.S. 1.4401 Nitrided |
| 07 | Stem packing 1 | Graphite |
| 07a | Stem packing 2 | Graphite |
| 08a | Gland packing 1 | S.S. 1.4401 |
| 08b | Gland packing 2 | S.S. 1.4401 |
| 09 | Spring washer | S.S. 1.4310 |
| 14 | Body seal 1 | Graphite |
| 19 | Spring | S.S. 1.4401 |
| 20 | Antistatic ball | S.S. 1.4401 |
| 22 | Stop pin | S.S. 1.4401 |
| 31 | Bearing | Carbongraphite |
| 33 | Support bearing | S.S. 1.4401 |
| 34 | Body seal 2 | Graphite |
| 41 | Stud | A4-70 |
| 42 | Nut | A4-70 |
| 44b | Ring seat 2 | S.S. 1.4401 |
| 45 | Spring seat | Inconel X750 |
| 46 | Seat seal | Graphite |
| 47 | Metal seat | 1.4401+Cr-Carbide |
| 50 | Subjection ring | S.S. 1.4301 |
| 86 | Drain plug | S.S. 1.4401 |
| 86a | Vent plug | S.S. 1.4401 |
| 109 | Cover seal | Graphite |
| 110 | Subjection ring seal | S.S. 1.4401 Nitrided |
| 149 | ISO cover | S.S. 1.4401 |
| 151 | Body cover 1 | S.S. 1.4401 |
| 152 | Body cover bolt | A4-70 |
| 153 | ISO cover bolt | A4-70 |
| 165 | Stem bearing | Carbongraphite |

General features

- Full trunnion.
- Three pieces.
- Full bore.
- Metal to Metal.
- Bidirectional.
- Spring loaded seat system.
- Anti Blow out proof stem.
- Autoadjustable packing.
- Anti static device.
- Self-cavity pressure relief.
- Double Block and Bleed.

Standards

- Top flange ISO 5211
- Flanges EN 1092-01
- Face to face EN-12982
- Testing EN-12266, ISO 5208
- Design EN-12516, ISO 17292

Official approvals

- CERTIFICATE FIRE SAFE
- TA-LUFT VDI 2440
- ISO 15848-1
- ATEX 2014/34/EU
- PED 2014/68/EU
- SIL 3 CAPABLE

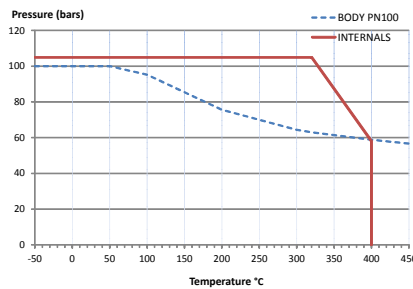

PEKOS GROUP CERTIFICATES:
 ISO 9001-2008 / 2014/68/EU / API-6D



DIMENSIONS & Technical information

| DN | PN | D | L | E | A | B | C | F | H | G | V | X | Y | Z | n x d | ISO 5211 | Torque | MAST | Weight |
|-----|-----|-----|------|-----|-----|-----|----|-----|----|----|----|----|----|----|---------|----------|--------|---------|--------|
| 100 | 100 | 100 | 430 | 265 | 162 | 210 | 36 | 155 | ** | ** | 36 | 27 | 35 | 44 | 8 x 30 | F14-1 | 1280 | 1989,7 | 103 |
| 125 | 100 | 125 | 500 | 315 | 188 | 250 | 40 | 191 | ** | ** | 36 | 27 | 35 | 44 | 8 x 33 | F14-1 | 2065 | 1989,7 | 158 |
| 150 | 100 | 150 | 550 | 355 | 218 | 290 | 44 | 229 | ** | ** | 48 | 36 | 40 | 63 | 12 x 33 | F16-1 | 2850 | 4716,3 | 212 |
| 200 | 100 | 200 | 650 | 430 | 285 | 360 | 52 | 295 | ** | ** | 60 | 46 | 60 | 73 | 12 x 36 | F16 | 4445 | 9359,9 | 378 |
| 250 | 100 | 250 | 775 | 505 | 345 | 430 | 60 | 330 | ** | ** | 60 | 46 | 60 | 68 | 12 x 39 | F25-1 | 5690 | 9359,9 | 632 |
| 300 | 100 | 300 | 900 | 585 | 410 | 500 | 68 | 400 | ** | ** | 72 | 55 | 70 | 83 | 16 x 42 | F25 | 6800 | 16131,2 | 678 |
| 350 | 100 | 350 | 1025 | 655 | 465 | 560 | 74 | 460 | ** | ** | 72 | 55 | 70 | 83 | 16 x 48 | F30-1 | 11560 | 16131,2 | 1134 |

** Depending on service conditions.

* Dimensions are in mm.

* Torque & MAST are in Nm.

* Weight is in Kilogram

* Torque values have been measured ΔP at maximum rating at room temperature

DS-763

Rev.3