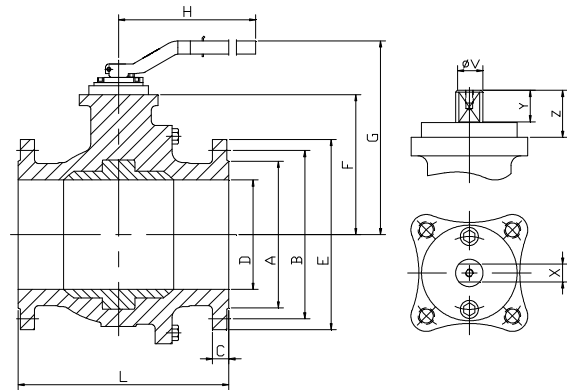
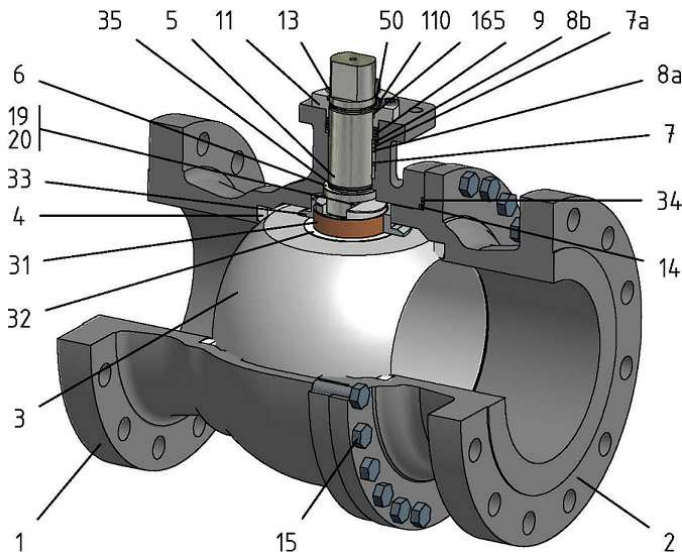

**FIG.ZG 36 SSSGV CL300 6"-12"**



Position	Description	Material
01	Body 1	S.S. A351 CF8M
02	Body 2	S.S. A351 CF8M
03	Ball	S.S. A351 CF8M
04	Seat	PTFE+CG
05	Stem	S.S. AISI 316
06	Stem seal	PTFE+CG
07	Stem packing 1	PTFE+CG
07a	Stem packing 2	Graphite
08a	Gland packing 1	S.S. AISI 316
08b	Gland packing 2	S.S. AISI 316
09	Spring washer	S.S. AISI 301
11	Cover	S.S. A351 CF8M
13	Cover bolt	A4-70
14	Body seal 1	PTFE+CG
15	Body bolt	A193 B8M
16	Handle	WCB
17	Handle bolt	1.045(8.8)
19	Spring	S.S. AISI 316
20	Antistatic ball	S.S. AISI 316
23	Handle pin	S.S. AISI 420
24	Lengthening handle	A570
31	Bearing	PTFE
32	Bearing disk	PTFE+FG
33	Support bearing	S.S. AISI 316
34	Body seal 2	Graphite
35	O ring stem	FKM
50	Subjection ring	S.S. AISI 420
110	Subjection ring seal	S.S. AISI 316 Nitrided
165	Stem bearing	PTFE+FG

**General features**

- Guided ball.
- Split body.
- Full bore.
- Soft seat.
- Bidirectional.
- Anti Blow out proof stem.
- Autoadjustable packing.
- Anti static device.
- Self-cavity pressure relief.

**Standards**

- Top flange ISO 5211
- Flanges ANSI B16.5
- Face to face ANSI B16.10
- Testing API 598, API 6D, BS 6755-1
- Design API 6D, B16.34
- Materials according to NACE MR0175

**Official approvals**

- CERTIFICATE FIRE SAFE TA-LUFT
- ATEX 94-9EC
- API 6D.
- PED 97/23/CE.
- SIL 3 CAPABLE
- EN 161/EN 264

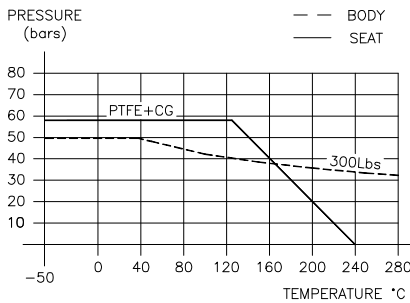

**PEKOS GROUP CERTIFICATES:**  
 ISO 9001-2008 / 97-23-CE / API-6D



**DIMENSIONS & Technical information**

DN	CL	D	L	E	A	B	C	F	H	G	V	X	Y	Z	n x d	ISO 5211	Torque	MAST	Weight
6"	300	150	403	320	216	270	38	176	740	269	36	27	35	50	12 x 22	F12	710	1047,2	105,0
8"	300	200	502	380	270	330	43	245	750	338	48	36	40	63	12 x 25	F14	1470	2482,2	179,0
10"	300	250	568	445	324	387	49	285	-	-	48	36	40	63	16 x 29	F14	1950	2482,2	287,0
12"	300	300	648	520	381	451	52	329	-	-	48	36	40	63	16 x 32	F14	2180	2482,2	480,0

\*\* Depending on service conditions.

\* Dimensions are in mm.

\* Torque & MAST are in Nm

\* Weight is in Kilograms

\* Torque values have been measured ΔP at maximum rating at room temperature

**DS-712**  
 Rev.2