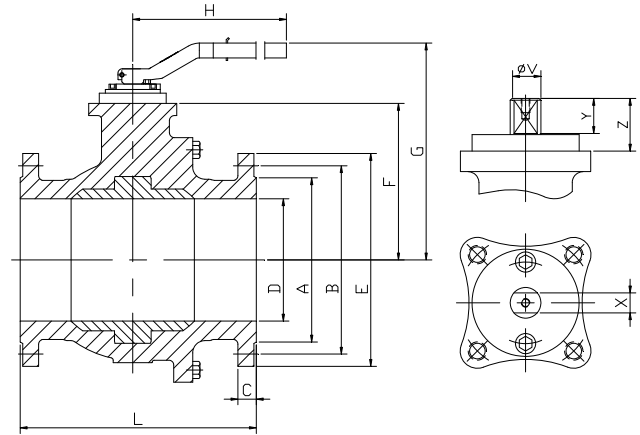
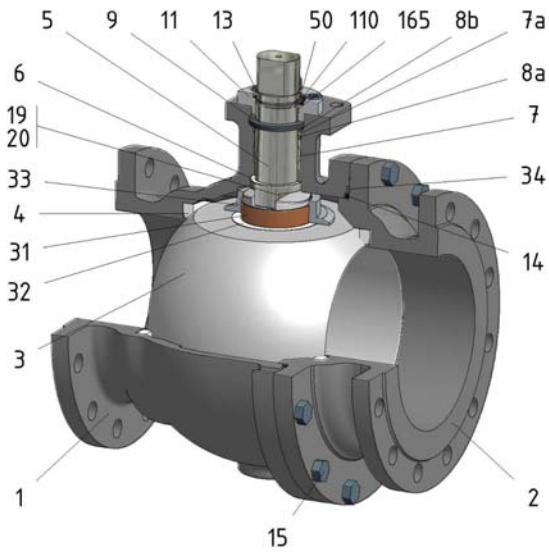

**FIG.ZG 06 RRRG PN40 DN150/300 F5**



Position	Description	Material
01	Body 1	S.S. 1.4408
02	Body 2	S.S. 1.4408
03	Ball	S.S. 1.4408
04	Seat	PTFE+FG
05	Stem	S.S. 1.4401
06	Stem seal	PTFE+FG
07	Stem packing 1	PTFE+FG
07a	Stem packing 2	Graphite
08	Gland packing	S.S. 1.4401
09	Spring washer	S.S. 1.4310
11	Cover	S.S. 1.4408
13	Cover bolt	A4-70
14	Body seal 1	PTFE+FG
15	Body bolt	A4-70
16	Handle	WCB
17	Handle bolt	1.045(8.8)
19	Spring	S.S. 1.4401
20	Antistatic ball	S.S. 1.4401
23	Handle pin	S.S. 1.4021
24	Lengthening handle	S.S. 1.0254
31	Bearing	PTFE
32	Bearing disk	PTFE+FG
33	Support bearing	S.S. 1.4401
34	Body seal 2	Graphite
50	Subjection ring	S.S. 1.4301
110	Subjection ring seal	S.S. 1.4401 Nitrided
165	Stem bearing	PTFE+FG

**General features**

- Guided ball.
- Split body.
- Full bore.
- Soft seat.
- Bidirectional.
- TA-LUFT.
- Anti Blow out proof stem.
- Autoadjustable packing.
- Anti static device.
- Self-cavity pressure relief.

**Standards**

- Top flange ISO 5211
- Flanges EN 1092-01
- Face to face EN 558
- Testing EN-12266, ISO 5208
- Design EN-12516, ISO 17292

**Official approvals**

- CERTIFICATE FIRE SAFE
- TÜV.AD-MERKBLATT WO TA-LUFT
- ATEX 94-9EC
- PED 97/23/CE.
- SIL 3 CAPABLE
- EN 161/EN 264

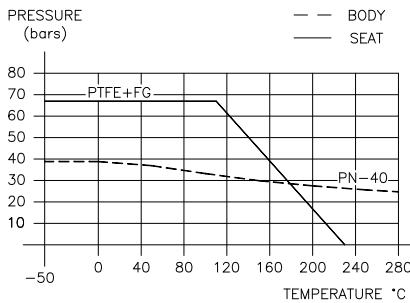

**PEKOS GROUP CERTIFICATES:**  
ISO 9001-2008 / 97-23-CE / API-6D



**DIMENSIONS & Technical information**

DN	PN	D	L	E	A	B	C	F	H	G	V	X	Y	Z	n x d	ISO 5211	Torque	MAST	Weight
150	40	150	350	300	218	250	28	176	740	284	36	27	35	50	8 x 26	F12	530	1073,4	83,0
200	40	200	400	375	285	320	34	245	750	362	48	36	40	63	12 x 30	F14	1100	2544,3	147,0
250	40	250	450	450	345	385	38	285	-	-	48	36	40	63	12 x 33	F14	1460	2544,3	254,0
300	40	300	500	515	410	450	42	329	-	-	48	36	40	63	16 x 33	F14	1640	2544,3	372,0

\*\* Depending on service conditions.

\* Dimensions are in mm.

\* Torque & MAST are in Nm.

\* Weight is in Kilogram

\* Torque values have been measured ΔP at maximum rating at room temperature

**DS-1538**  
Rev.1