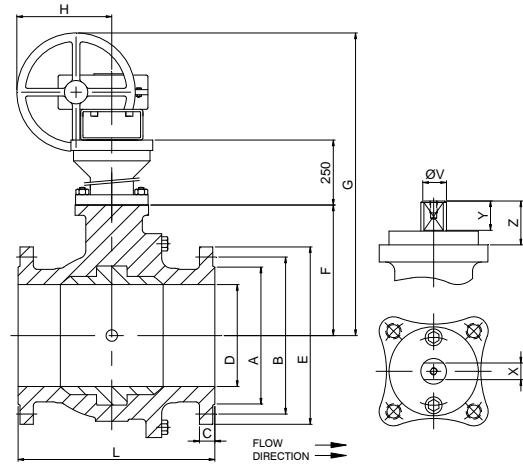
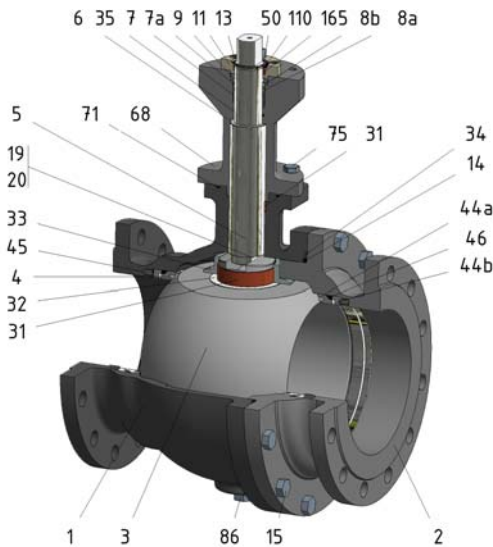

FIG.ZFGOSU 06 KTTGN PN40 DN150-300 F5



Position	Description	Material
01	Body 1	S.S. 1.4408
02	Body 2	S.S. 1.4408
03	Ball	S.S. 1.4408
04	Seat	PCTFE
05	Stem	XM-19
06	Stem seal	PCTFE
07	Stem packing 1	PTFE
07a	Stem packing 2	Graphite
08a	Gland packing 1	S.S. 1.4401
08b	Gland packing 2	S.S. 1.4401
09	Spring washer	S.S. 1.4310
11	Cover	S.S. 1.4408
13	Cover bolt	A4-70
14	Body seal 1	PTFE
15	Body bolt	A4-70
19	Spring	S.S. 1.4401
20	Antistatic ball	S.S. 1.4401
31	Bearing	PTFE
32	Bearing disk	PTFE+FG
33	Support bearing	S.S. 1.4401
34	Body seal 2	Graphite
35	O ring stem	NBR
44a	Ring seat 1	S.S. 1.4401
44b	Ring seat 2	S.S. 1.4401
45	Spring seat	Inconel X750
46	Seat seal	Graphite
50	Subjection ring	S.S. 1.4021
68	Stem extension casing	S.S. 1.4401
71	Extension seal	Graphite
75	Extension bolt	A4-70
86	Drain plug	S.S. 1.4401
86a	Vent plug	S.S. 1.4401
110	Subjection ring seal	S.S. 1.4401 Nitrided
165	Stem bearing	PTFE+FG

General features

Full trunnion.
Cryogenic.
Split body.
Full bore.
Soft seat.
Unidirectional.
Spring loaded seat system.
Anti Blow out proof stem.
Autoadjustable packing.
Anti static device.
Self-cavity pressure relief.
Double Block and Bleed.
Degreased

Standards

Top flange ISO 5211
Flanges EN 1092-01
Face to face EN 558
Design EN-12516, ISO 17292
Testing EN-12266, ISO 5208

Official approvals

CRYOGENIC
CERTIFICATE FIRE SAFE
TA-LUFT VDI 2440
ISO 15848-1
ATEX 2014/34/EU
PED 2014/68/EU
SIL 3 CAPABLE

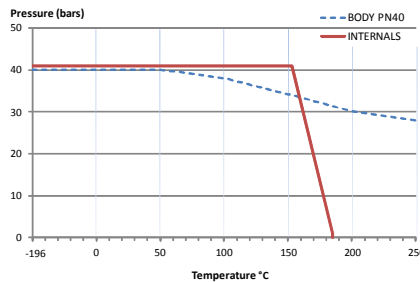

PEKOS GROUP CERTIFICATES:

ISO 9001-2008 / 2014/68/EU / API-6D



DIMENSIONS & Technical information

DN	PN	D	L	E	A	B	C	F	H	G	V	X	Y	Z	n x d	ISO 5211	Torque	MAST	Weight
150	40	150	350	300	218	250	28	176	271	797	36	27	35	44	8 x 26	F14-1	945	1989,7	132
200	40	200	400	375	285	320	34	245	336	927	48	36	40	63	12 x 30	F16-1	1485	4716,3	233
250	40	250	450	450	345	385	38	285	436	973	48	36	40	63	12 x 33	F16-1	1930	4716,3	402
300	40	300	500	515	410	450	42	329	436	1017	48	36	40	63	16 x 33	F16-1	2490	4716,3	593

** Depending on service conditions.

* Dimensions are in mm.

* Torque & MAST are in Nm.

* Weight is in Kilogram

* Torque values have been measured ΔP at maximum rating at room temperature

DS-3643
Rev.2