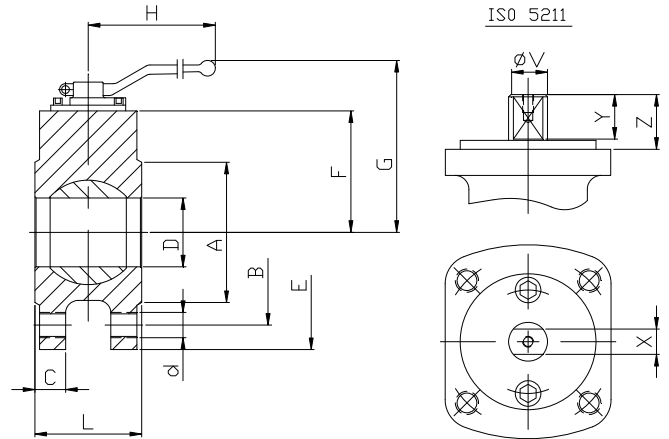
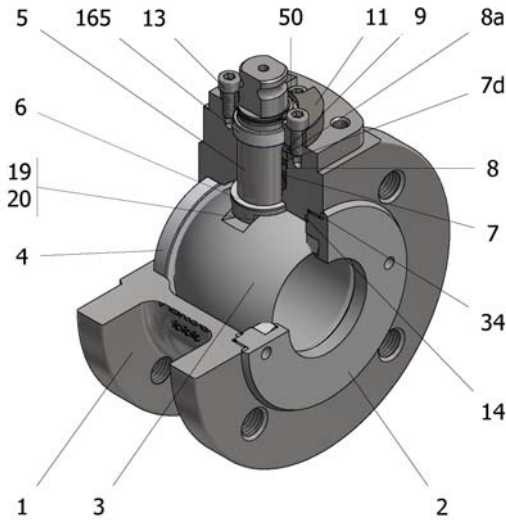

FIG.Z 94 TTTGV PN16/PN40 DN20-DN80



Position	Description	Material
01	Body 1	C.S. 1.0619
02	Body 2	C.S. 1.0352
03	Ball	S.S. 1.4408
04	Seat	PTFE
05	Stem	S.S. 1.4401
06	Stem seal	PTFE+FG
07	Stem packing	PTFE
07d	Stem packing d	Graphite
08	Gland packing	S.S. 1.4401
08a	Gland packing a	S.S. 1.4401
09	Spring washer	S.S. 1.4310
11	Cover	S.S. 1.4408
13	Cover bolt	A4-70
14	Body seal 1	PTFE
16	Handle	WCB
17	Handle bolt	1.045(8.8)
19	Spring	S.S. 1.4401
20	Antistatic ball	S.S. 1.4401
34	Body seal 2	Graphite
35	O ring stem	FKM
50	Subjection ring	S.S. 1.4021
165	Stem guide seal	PTFE+FG

General features

Short measure
Fire Safe Design
Floating ball.
End entry.
Full bore.
Soft seat.
Bidirectional.
Anti Blow out proof stem.
Autoadjustable packing.
Anti static device.
Self-cavity pressure relief.

Standards

Top flange ISO 5211
Flanges EN 1092-01
Testing EN-12266, ISO 5208
Design EN-12516, ISO 17292,
DIN 28140
Face to face EN 558 serie 100

Official approvals

CERTIFICATE FIRE SAFE
TA-LUFT VDI 2440
ISO 15848-1
ATEX 2014/34/EU
PED 2014/68/EU
SIL 3 CAPABLE

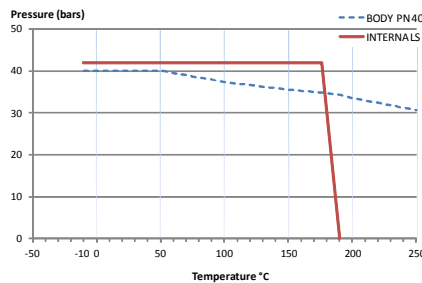

PEKOS GROUP CERTIFICATES:

ISO 9001-2008 / 2014/68/EU / API-6D



DIMENSIONS & Technical information

DN	PN	D	L	E	A	B	C	F	H	G	V	X	Y	Z	n x d	ISO 5211	Torque	MAST	Weight
20	40	20	39	105	60	75	-	53	185	113	14	11	11	14	4 x M12	F05/1	14	94,5	1,9
25	40	25	44	115	68	85	18	56	185	116	14	11	11	14	4 x M12	F05/1	18	94,5	2,7
32	40	32	52	142	76	100	18	64	185	123	18	14	17	20	4 x M16	F05/2	30	94,5	5,3
40	40	40	64	150	88	110	18	75	293	139	22	17	20	30	4 x M16	F07	40	250,3	6,5
50	40	50	83	165	102	125	20	83	293	147	22	17	20	30	4 x M16	F07	65	250,3	7,4
65	40	65	105	185	122	145	22	95	293	159	22	17	20	30	8 x M16	F07	85	250,3	10,3
80	40	80	121	200	138	160	24	112	450	198	28	22	22	40	8 x M16	F10	130	522,5	14,4

** Depending on service conditions.

* Dimensions are in mm.

* Torque & MAST are in Nm.

* Weight is in Kilogram

* Torque values have been measured ΔP at maximum rating at room temperature

DS-4122

Rev.5