

## FIG.Z 84 TTG PN16 DN25/200 L/T

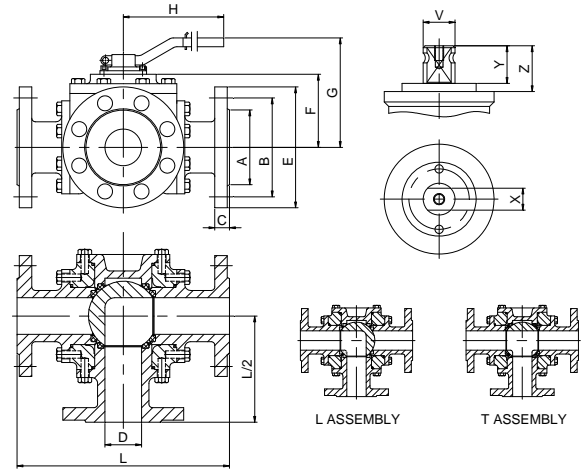
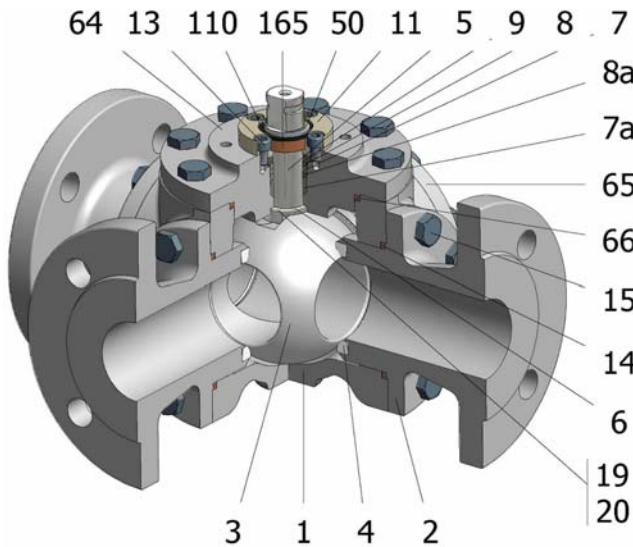

Position	Description	Material
01	Body 1	C.S. 1.0619
02	Body 2	C.S. 1.0619
03	Ball	S.S. 1.4408
04	Seat	PTFE
05	Stem	S.S. 1.4401
06	Stem seal	PTFE+FG
07	Stem packing 1	PTFE
07a	Stem packing 2	Graphite
08	Gland packing	S.S. 1.4401
08a	Gland packing 1	S.S. 1.4401
09	Spring washer	S.S. 1.4310
11	Cover	S.S. 1.4408
13	Cover bolt	A4-70
14	Body seal 1	Graphite
15	Body bolt	A2-70
16	Handle	WCB
17	Handle bolt	1.045(8.8)
19	Spring	S.S. 1.4401
20	Antistatic ball	S.S. 1.4401
50	Subjection ring	S.S. 1.4021
64	Body cover	C.S. 1.0619
65	Body blind	C.S. 1.0619
66	Body cover seal	Graphite
110	Subjection ring seal	S.S. 1.4401 Nitrided
165	Stem bearing	PTFE+FG

### General features

Floating ball.  
Split body.  
Full bore.  
Soft seat.  
Three way  
Fire Safe Design  
Anti Blow out proof stem.  
Autoadjustable packing.  
Anti static device.  
Self-cavity pressure relief.

### Standards

Top flange ISO 5211  
Flanges EN 1092-01  
Testing EN-12266, ISO 5208  
Design EN-12516, ISO 17292

### Official approvals

TA-LUFT VDI 2440  
ISO 15848-1  
ATEX 2014/34/EU  
PED 2014/68/EU  
SIL 3 CAPABLE

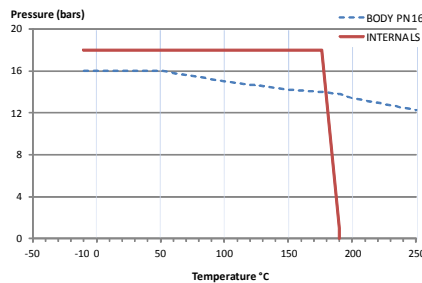

### PEKOS GROUP CERTIFICATES:

ISO 9001-2008 / 2014/68/EU /API-6D



### DIMENSIONS & Technical information

DN	PN	D	L	E	A	B	C	F	H	G	V	X	Y	Z	n x d	ISO 5211	Torque	MAST	Weight
25	16	25	230	115	68	85	18	67	185	117	18	14	17	19,5	4 x 14	F05	21	94,5	14,0
40	16	40	260	150	88	110	18	82	293	136	22	17	20	30	4 x 18	F07	47	250,4	22,0
50	16	50	290	165	102	125	20	90	293	144	22	17	20	30	4 x 18	F07	69	250,4	30,0
65	16	65	340	185	122	145	18	109	450	182	28	22	22	40	8 x 18	F10	83	522,5	47,0
80	16	80	380	200	138	160	20	132	740	205	36	27	35	50	8 x 18	F12	128	1073,4	65,0
100	16	100	430	220	158	180	20	147	740	220	36	27	35	50	8 x 18	F12	165	1073,4	95,0
150	16	150	480	285	212	240	22	216	-	-	48	36	40	63	8 x 22	F14	570	2544,3	180,0
200	16	200	600	340	268	295	24	258	-	-	48	36	40	63	12 x 22	F14	810	2544,3	300,0

\*\* Depending on service conditions.

\* Dimensions are in mm.

\* Torque & MAST are in Nm.

\* Weight is in Kilogram

\* Torque values have been measured  $\Delta P$  at maximum rating at room temperature

DS-609  
Rev.9