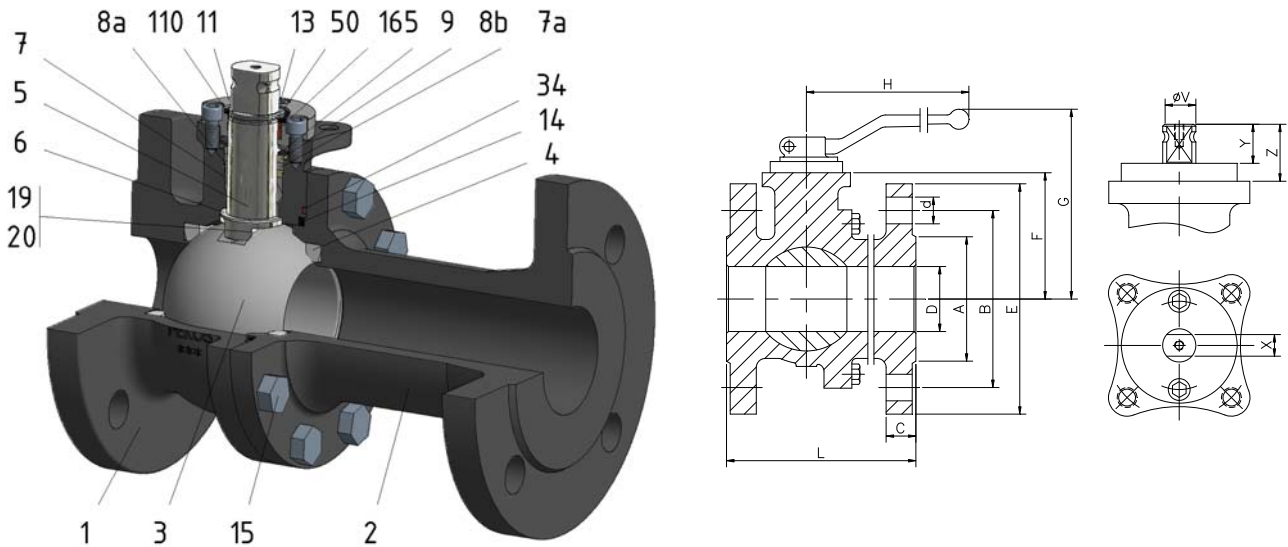

FIG.Z 29 TTTG PN40 DN15/125 F1



Position	Description	Material
01	Body 1	C.S. 1.6220
02	Body 2	C.S. 1.6220
03	Ball	S.S. 1.4408
04	Seat	PTFE
05	Stem	S.S. 1.4401
06	Stem seal	PTFE+FG
07	Stem packing 1	PTFE
07a	Stem packing 2	Graphite
08a	Gland packing 1	S.S. 1.4401
08b	Gland packing 2	S.S. 1.4401
09	Spring washer	S.S. 1.4310
11	Cover	S.S. 1.4408
13	Cover bolt	A4-70
14	Body seal 1	PTFE
15	Body bolt	A2-70
16	Handle	WCB
17	Handle bolt	1.045(8.8)
19	Spring	S.S. 1.4401
20	Antistatic ball	S.S. 1.4401
34	Body seal 2	Graphite
50	Subjection ring	S.S. 1.4021
110	Subjection ring seal	S.S. 1.4401 Nitrided
165	Stem bearing	PTFE+FG

General features

Floating ball.
 Split body.
 Full bore.
 Soft seat.
 Bidirectional.
 Anti Blow out proof stem.
 Autoadjustable packing.
 Anti static device.
 Self-cavity pressure relief.

Standards

Top flange ISO 5211
 Flanges EN 1092-01
 Face to face EN 558
 Testing EN-12266, ISO 5208
 Design EN-12516, ISO 17292

Official approvals

CERTIFICATE FIRE SAFE
 TA-LUFT VDI 2440
 ISO 15848-1
 ATEX 2014/34/EU
 PED 2014/68/EU
 SIL 3 CAPABLE
 EN 161/EN ISO 23553-1

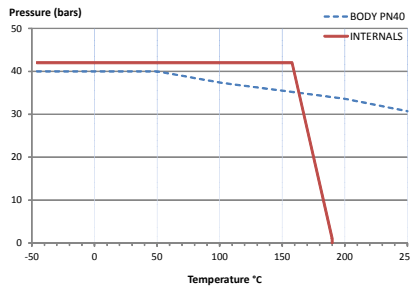

PEKOS GROUP CERTIFICATES:

ISO 9001-2008 / 2014/68/EU /API-6D



DIMENSIONS & Technical information

DN	PN	D	L	E	A	B	C	F	H	G	V	X	Y	Z	n x d	ISO 5211	Torque	MAST	Weight
15	40	15	130	95	45	65	16	52	185	100	14	11	11	13,5	4 x 14	F05	12	43,5	3,2
20	40	20	150	105	58	75	18	54	185	102	14	11	11	13,5	4 x 14	F05	14	43,5	4,3
25	40	25	160	115	68	85	18	60	185	110	18	14	17	19,5	4 x 14	F05	18	94,5	5,3
32	40	32	180	140	78	100	18	65	185	115	18	14	17	19,5	4 x 18	F05	30	94,5	7,2
40	40	40	200	150	88	110	18	75	293	129	22	17	20	30	4 x 18	F07	40	250,4	9,3
50	40	50	230	165	102	125	20	83	293	137	22	17	20	30	4 x 18	F07	65	250,4	13,0
65	40	65	290	185	122	145	22	96	293	150	22	17	20	30	8 x 18	F07	85	250,4	20,0
80	40	80	310	200	138	160	24	114	350	187	28	22	22	40	8 x 18	F10	130	522,5	26,0
100	40	100	350	235	162	190	24	128	350	201	28	22	22	40	8 x 22	F10	190	522,5	36,4
125	40	125	400	270	188	220	26	158	740	247	36	27	35	50	8 x 26	F12	350	1073,4	73,0

** Depending on service conditions.

* Dimensions are in mm.

* Torque & MAST are in Nm.

* Weight is in Kilogram

* Torque values have been measured ΔP at maximum rating at room temperature

DS-2083

Rev.5