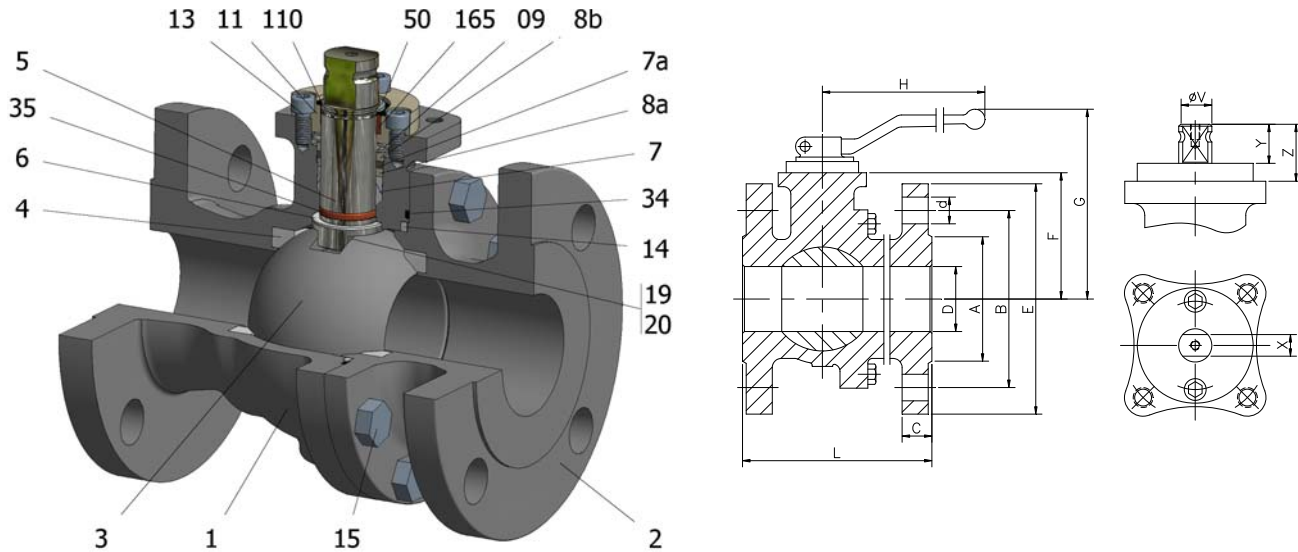

**FIG.Z 19 TTTGV CL150 1/2"-8"**



Position	Description	Material
01	Body 1	C.S. A352 LCC
02	Body 2	C.S. A352 LCC
03	Ball	S.S. A351 CF8M
04	Seat	PTFE
05	Stem	S.S. AISI 316
06	Stem seal	PTFE+FG
07	Stem packing 1	PTFE
07a	Stem packing 2	Graphite
08a	Gland packing	S.S. AISI 316
08b	Gland packing 1	S.S. AISI 316
09	Spring washer	S.S. AISI 301
11	Cover	S.S. A351 CF8M
13	Cover bolt	S.S. (316)
14	Body seal 1	PTFE
15	Body bolt	A320 L7M
16	Handle	WCB
17	Handle bolt	1.045(8.8)
19	Spring	S.S. AISI 316
20	Antistatic ball	S.S. AISI 316
34	Body seal 2	Graphite
35	O ring stem	FKM
50	Subjection ring	S.S. AISI 420
110	Subjection ring seal	S.S. AISI 316 Nitrided
165	Stem bearing	PTFE+FG

**General features**

- Floating ball.
- Split body.
- Full bore.
- Soft seat.
- Bidirectional.
- Anti Blow out proof stem.
- Autoadjustable packing.
- Anti static device.
- Self-cavity pressure relief.

**Standards**

- Top flange ISO 5211
- Flanges ANSI B16.5
- Face to face ANSI B16.10
- Testing API 598, API 6D, BS 6755-1
- Design API 6D, B16.34
- Materials according to NACE MR0175

**Official approvals**

- CERTIFICATE FIRE SAFE
- TA-LUFT VDI 2440
- ISO 15848-1
- API 6D.
- ATEX 2014/34/EU
- PED 2014/68/EU
- SIL 3 CAPABLE
- EN 161/EN ISO 23553-1

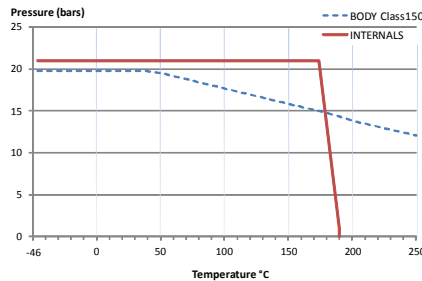

**PEKOS GROUP CERTIFICATES:**  
ISO 9001-2008 / 2014/68/EU / API-6D



**DIMENSIONS & Technical information**

DN	CL	D	L	E	A	B	C	F	H	G	V	X	Y	Z	n x d	ISO 5211	Torque	MAST	Weight
1/2"	150	15	108	90	35	60	11	45	185	106	14	11	11	13,5	4 x 16	F05	9	42,4	2,5
3/4"	150	20	117	100	43	70	12	47	185	108	14	11	11	13,5	4 x 16	F05	11	42,4	3,2
1"	150	25	127	110	51	79	14	52	185	113	18	14	17	19,5	4 x 16	F05	16	92,2	4,2
1 1/4"	150	32	140	115	64	89	15	57	185	118	18	14	17	19,5	4 x 16	F05	23	92,2	6,0
1 1/2"	150	40	165	125	73	98	16	75	293	145	22	17	20	30	4 x 16	F07	32	244,3	7,4
2"	150	50	178	150	92	121	17	83	293	153	22	17	20	30	4 x 19	F07	48	244,3	10,4
2 1/2"	150	65	190	180	105	140	19	96	293	166	22	17	20	30	4 x 19	F07	62	244,3	17,0
3"	150	80	203	190	127	152	21	113	350	199	28	22	22	40	4 x 19	F10	103	509,7	22,5
4"	150	100	229	230	157	191	25	128	350	221	28	22	22	40	8 x 19	F10	145	509,7	31,6
6"	150	150	394	280	216	241	27	176	740	285	36	27	35	50	8 x 22	F12	400	1047,2	81,1
8"	150	200	457	345	270	299	30	245	750	354	48	36	40	63	8 x 22	F14	720	2482,2	143,0

\*\* Depending on service conditions. \* Dimensions are in mm. \* Torque & MAST are in Nm \* Weight is in Kilogram  
\* Torque values have been measured ΔP at maximum rating at room temperature

**DS-1080**  
Rev.5