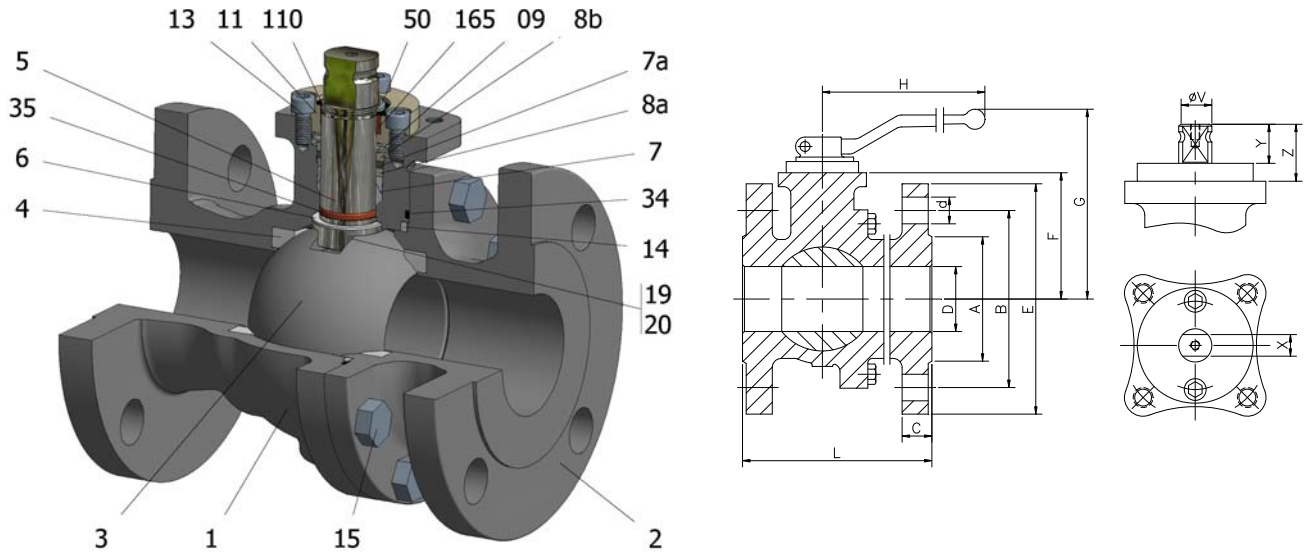

FIG.Z 14 SSSGV CL150 1/2"-8"



Position	Description	Material
01	Body 1	C.S. A216 WCC
02	Body 2	C.S. A216 WCC
03	Ball	S.S. A351 CF8M
04	Seat	PTFE (modified)+CG
05	Stem	S.S. AISI 316
06	Stem seal	PTFE (modified)+CG
07	Stem packing 1	PTFE (modified)+CG
07a	Stem packing 2	Graphite
08a	Gland packing	S.S. AISI 316
08b	Gland packing 1	S.S. AISI 316
09	Spring washer	S.S. AISI 301
11	Cover	S.S. A351 CF8M
13	Cover bolt	S.S. (316)
14	Body seal 1	PTFE (modified)+CG
15	Body bolt	A193 B7M
16	Handle	WCB
17	Handle bolt	1.045(8.8)
19	Spring	S.S. AISI 316
20	Antistatic ball	S.S. AISI 316
34	Body seal 2	Graphite
35	O ring stem	FKM
50	Subjection ring	S.S. AISI 420
110	Subjection ring seal	S.S. AISI 316 Nitrided
165	Stem bearing	PTFE (modified)+FG

General features

Floating ball.
Split body.
Full bore.
Soft seat.
Bidirectional.
Anti Blow out proof stem.
Autoadjustable packing.
Anti static device.
Self-cavity pressure relief.

Standards

Top flange ISO 5211
Flanges ANSI B16.5
Face to face ANSI B16.10
Testing API 598, API 6D, BS 6755-1
Design API 6D, B16.34
Materials according to NACE MR0175

Official approvals

CERTIFICATE FIRE SAFE
TA-LUFT VDI 2440
ISO 15848-1
API 6D.
ATEX 2014/34/EU
PED 2014/68/EU
SIL 3 CAPABLE
EN 161/EN ISO 23553-1

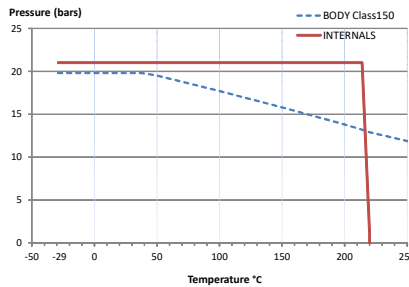

PEKOS GROUP CERTIFICATES:

ISO 9001-2008 / 2014/68/EU / API-6D



DIMENSIONS & Technical information

DN	CL	D	L	E	A	B	C	F	H	G	V	X	Y	Z	n x d	ISO 5211	Torque	MAST	Weight
1/2"	150	15	108	90	35	60	11	51	185	106	14	11	11	13,5	4 x 16	F05	11	42,4	2
3/4"	150	20	117	100	43	70	12	53	185	108	14	11	11	13,5	4 x 16	F05	13	42,4	3
1"	150	25	127	110	51	79	14	59	185	113	18	14	17	19,5	4 x 16	F05	19	92,2	4
1 1/4"	150	32	140	115	64	89	15	63	185	118	18	14	17	19,5	4 x 16	F05	28	92,2	6
1 1/2"	150	40	165	125	73	98	16	75	293	145	22	17	20	30	4 x 16	F07	38	244,3	7
2"	150	50	178	150	92	121	17	83	293	153	22	17	20	30	4 x 19	F07	58	244,3	10
2 1/2"	150	65	190	180	105	140	19	96	293	166	22	17	20	30	4 x 19	F07	74	244,3	17
3"	150	80	203	190	127	152	21	113	350	199	28	22	22	40	4 x 19	F10	124	509,7	22
4"	150	100	229	230	157	191	25	128	350	221	28	22	22	40	8 x 19	F10	174	509,7	32
6"	150	150	394	280	216	241	27	176	740	285	36	27	35	50	8 x 22	F12	480	1047,2	81
8"	150	201	457	345	270	299	30	245	750	354	48	36	40	63	8 x 22	F14	864	2482,2	143

** Depending on service conditions.

* Dimensions are in mm.

* Torque & MAST are in Nm

* Weight is in Kilograms

* Torque values have been measured ΔP at maximum rating at room temperature